

## PCM CODEC

### FEATURES

- 2.7-V to 3.3-V Operation
- Designed for Analog and Digital Wireless Handsets and Telecommunications Applications
- Two Differential Microphone Inputs
- Differential Earphone Outputs and One Single-Ended Earphone Output
- Earphone and Microphone Mute
- Programmable Transmit, Receive, and Sidetone Paths With Extended Gain and Attenuation Ranges
- Programmable for 15-Bit Linear Data or 8-Bit Companded ( $\mu$ -law and A-law) Mode
- Supports PCM Clock Rates of 128 kHz and 2.048 MHz
- Pulse Density Modulated (PDM) Buzzer Output
- On-Chip I<sup>2</sup>C Bus, Which Provides Simple, Standard, Two-Wire Serial Interface With Digital ICs
- Dual-Tone Multifrequency (DTMF) and Single-Tone Generator Capable of up to 8-kHz Tone With Three Selectable Resolutions of 7.8125 Hz, 15.625 Hz, and 31.25 Hz
- 2-Channel Auxiliary Multiplexer (MUX) (Analog Switch)<sup>†</sup>

- Capable of Driving 32  $\Omega$  Down to a 8- $\Omega$  Speaker
- Programmable Power Down Modes
- Pin Compatible to the TLV320AIC1103 and TLV320AIC1109 Devices for TQFP Only
- Available in a 32-Pin Thin Quad Flatpack (TQFP) Package and MicroStar Junior™ BGA

### APPLICATIONS

- Digital Handset
- Digital Headset
- Cordless Phones
- Digital PABX
- Digital Voice Recording

### DESCRIPTION

The TLV320AIC1110 provides extended gain and attenuation flexibility for transmit, receive, and sidetone paths. A differential earphone output is capable of driving speaker loads as low as 8  $\Omega$  for use in speaker phone applications. The single tone function on the TLV320AIC1110 generates a single tone output of up to 8 kHz. The resolution of the DTMF tone is also selectable to 7.8125 Hz, 15.625 Hz, or 31.25 Hz through the interface control. The analog switch provides more control capabilities for voice-band audio processor (PCM codec).



This device contains circuits to protect its inputs and outputs against damage due to high static voltages or electrostatic fields. These circuits have been qualified to protect this device against electrostatic discharges (ESD) of up to 2 kV according to MIL-STD-883C, Method 3015; however, it is advised that precautions be taken to avoid application of any voltage higher than maximum-rated voltages to these high-impedance circuits. During storage or handling, the device leads should be shorted together or the device should be placed in conductive foam. In a circuit, unused inputs should always be connected to an appropriated logic voltage level, preferably either V<sub>CC</sub> or ground. Specific guidelines for handling devices of this type are contained in the publication *Guidelines for Handling Electrostatic-Discharge-Sensitive (ESDS) Devices and Assemblies* available from Texas Instruments.



Please be aware that an important notice concerning availability, standard warranty, and use in critical applications of Texas Instruments semiconductor products and disclaimers thereto appears at the end of this data sheet.

<sup>†</sup>These options are available on some devices. Please see the table of comparison for the last two generations of PCM codecs.

MicroStar Junior is a trademark of Texas Instruments.

All other trademarks are the property of their respective owners.

## DESCRIPTION (Continued)

The PCM codec is an analog-digital interface for voice band signals designed with a combination of coders and decoders (codecs) and filters. It is a low-power device with companding options and programming features, and it meets the requirements for communication systems, including the cellular phone. The device operates in either the 15-bit linear or 8-bit companded ( $\mu$ -law or A-Law) mode, which is selectable through the I<sup>2</sup>C interface.

A coder, an analog-to-digital converter or ADC, digitizes the analog voice signal, and a decoder, a digital-to-analog converter or DAC, converts the digital-voice signal to an analog output. The PCM codec provides a companding option to overcome the bandwidth limitations of telephone networks without degrading the sound quality. The human auditory system is a logarithmic system in which high amplitude signals require less resolution than low amplitude signals. Therefore, an 8-bit code word with nonuniform quantization ( $\mu$ -law or A-law) has the same quality as 13-bit linear coding. The PCM codec provides better digital code words by generating a 15-bit linear coding option.

The human voice is effective from a frequency range of 300 Hz to 3300 Hz in telephony applications. In order to eliminate unwanted signals, the PCM codec design has two types of filters that operate in both the transmit and receive path. A low-pass filter attenuates the signals over 4 kHz. A selectable high-pass filter cleans up the signals under 100 Hz. This reduces noise that may have coupled in from 50/60-Hz power cables. The high-pass filter is bypassed by selecting the corresponding register bit.

The PCM codec has many programming features that are controlled using a 2-wire standard serial I<sup>2</sup>C interface. This allows the device to interface with many digital ICs such as a DSP or a microprocessor. The device has seven registers: power control, mode control, transmit PGA, receive PGA, high DTMF, low DTMF, and auxiliary mode control. Some of the programmable features that can be controlled by I<sup>2</sup>C interface include:

- Transmit amplifier gain
- Receive amplifier gain
- Sidetone gain
- Volume control
- Earphone control
- PLL power control
- Microphone selection
- Transmit channel high-pass filter control
- Receive channel high-pass filter control
- Companding options and selection control
- PCM loopback
- DTMF control
- Pulse density modulated control

The PCM codec is also capable of generating its own internal clocks from a 2.048-MHz master clock input.

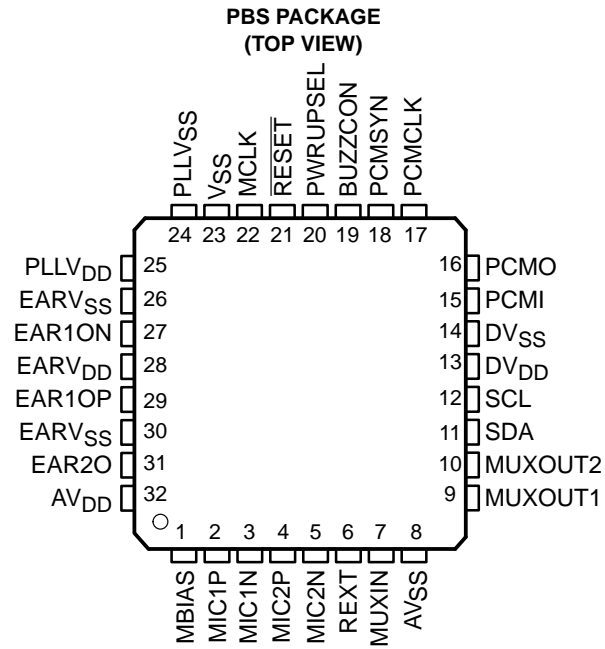

MicroStar Junior™ (GQE) PACKAGE  
(TOP VIEW)

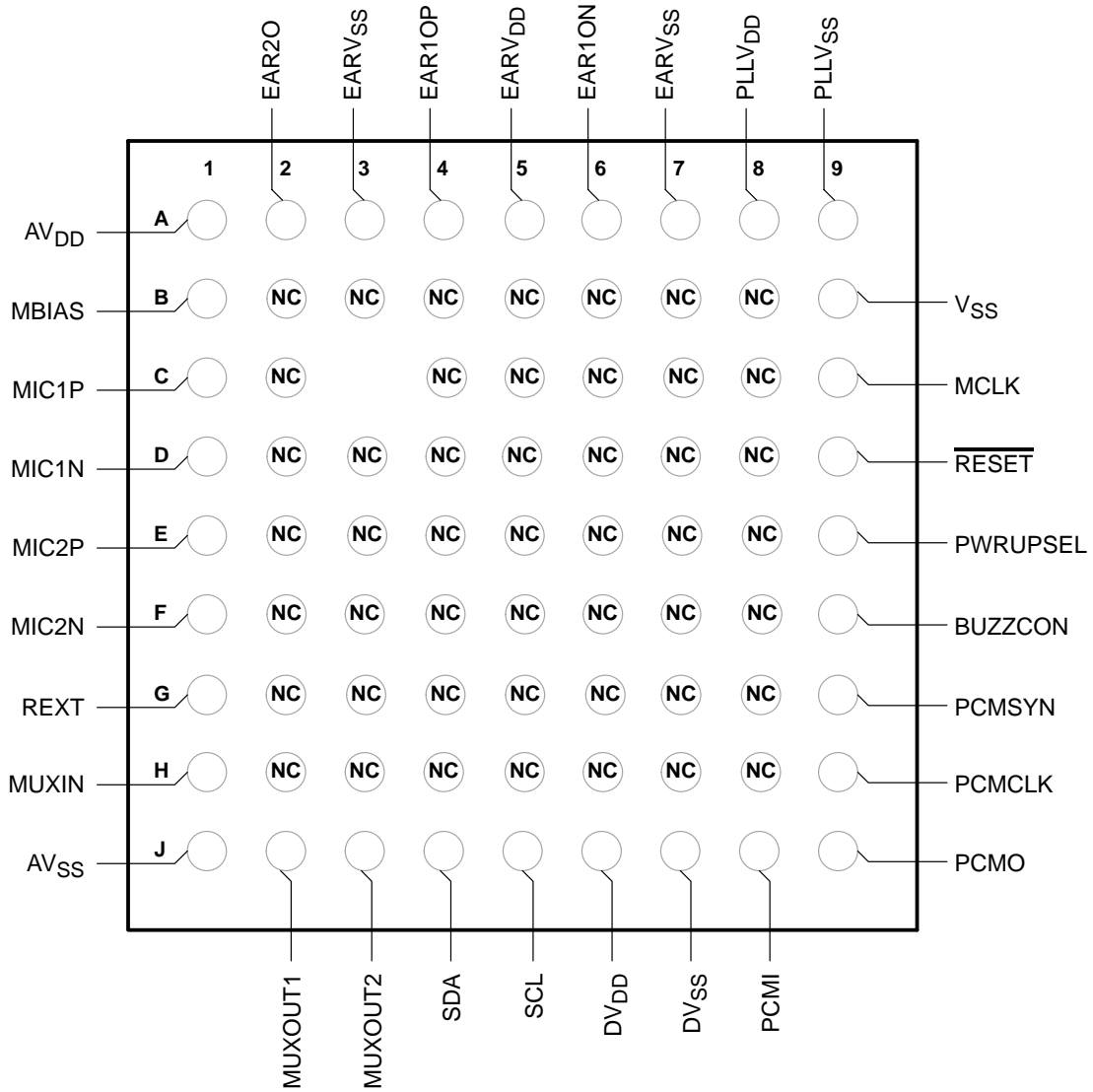

functional block diagram

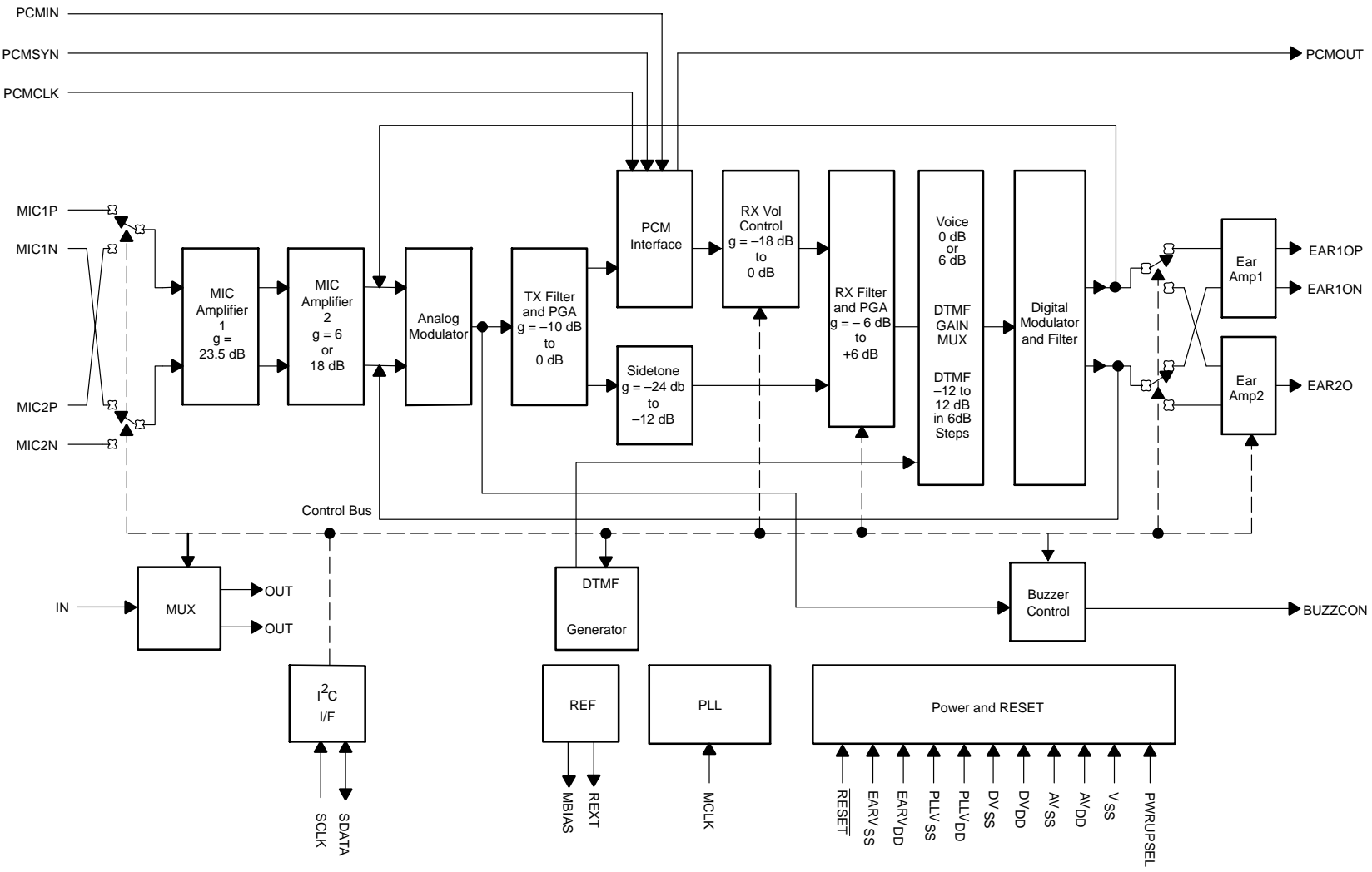

## detailed description

### power on/reset

The power for the various digital and analog circuits is separated to improve the noise performance of the device. An external reset must be applied to the active low  $\overline{\text{RESET}}$  terminal to assure reset upon power on and to bring the device to an operational state. After the initial power-on sequence, the device can be functionally powered up and powered down by writing to the power control register through the I<sup>2</sup>C interface. The device has a pin-selectable power up in the default mode option. The hardwired pin-selectable PWRUPSEL function allows the PCM codec to power up in the default mode and to be used without a microcontroller.

### reference

A precision band gap reference voltage is generated internally and supplies all required voltage references to operate the transmit and receive channels. The reference system also supplies bias voltage for use with an electret microphone at terminal MBIAS. An external precision resistor is required for reference current setting at terminal REXT.

### I<sup>2</sup>C control interface

The I<sup>2</sup>C interface is a two-wire bidirectional serial interface. The I<sup>2</sup>C interface controls the PCM codec by writing data to seven control registers:

- Power control
- Mode control
- Transmit PGA and sidetone control
- Receive PGA gain and volume control
- DTMF routing
- Tone selection control
- Auxiliary control

There are two power-up modes which may be selected at the PWRUPSEL terminal: (1) The PWRUPSEL state ( $V_{DD}$  at terminal 20) causes the device to power up in the default mode when power is applied. Without an I<sup>2</sup>C interface or controlling device, the programmable functions are fixed at the default gain levels, and functions such as the sidetone and DTMF are not accessible. (2) The PWRUPSEL state (ground at terminal 20) causes the device to go to a power-down state when power is applied. In this mode, an I<sup>2</sup>C interface is required to power up the device.

### phase-locked loop (PLL)

The phase-lock loop generates the internal clock frequency required for digital filters and modulators by phase locking to 2.048-MHz master clock input.

### PCM interface

The PCM interface transmits and receives data at the PCMO and PCMI terminals respectively. The data is transmitted or received at the PCMCLK speed once every PCMSYN cycle. The PCMCLK can be tied directly to the 128-kHz or 2.048-MHz master clock (MCLK). The PCMSYN can be driven by an external source or derived from the master clock and used as an interrupt to the host controller.

### microphone amplifiers

The microphone input is a switchable interface for two differential microphone inputs. The first stage is a low-noise differential amplifier that provides a gain of 23.5 dB. The second-stage amplifier has a selectable gain of 6 dB or 18 dB.

## detailed description (continued)

### analog modulator

The transmit channel modulator is a third-order sigma-delta design.

### transmit filter and PGA

The transmit filter is a digital filter designed to meet CCITT G.714 requirements. The device operates either in the 15-bit linear or 8-bit companded  $\mu$ -law or in the A-law mode, which is selectable through the I<sup>2</sup>C interface. The transmit PGA defaults to 0 dB.

### sidetone

A portion of the transmitted audio is attenuated and fed back to the receive channel through the sidetone path. The sidetone path defaults to the mute condition. The default gain of -12 dB is set in the sidetone control register. The sidetone path can be enabled by writing to the power control register.

### receive volume control

The receive volume control block acts as an attenuator with a range of -18 dB to 0 dB in 2-dB steps for control of the receive channel volume. The receive volume control gain defaults to 0 dB.

### receive filter and PGA

The receive filter is a digital filter that meets CCITT G.714 requirements with a high-pass filter that is selectable through the I<sup>2</sup>C interface. The device operates either in the 15-bit linear or the 8-bit  $\mu$ -law or the A-law companded mode, which is selectable through the I<sup>2</sup>C interface. The gain defaults to -4 dB, representing a 3-dBm level for a 32- $\Omega$  load impedance and the corresponding digital full scale PCMI code.

### digital modulator and filter

The second-order digital modulator and filter convert the received digital PCM data to the analog output required by the earphone interface.

### earphone amplifiers

The analog signal can be routed to either of two earphone amplifiers, one with differential output (EAR1ON and EAR1OP) and one with single-ended output (EAR2O). Clicks and pops are suppressed for EAR1 differential output only.

### tone generator

The tone generator provides generation of standard DTMF tones which are output to (1) the buzzer driver, as a PDM signal, (2) the receive path DAC for outputting through the earphone, or (3) as PCMO data. The integer value is loaded into one of two 8-bit registers, the high-tone register (04), or the low-tone register (05) (see the *Register Map Addressing* section). The tone output is 2 dB higher when applied to the high tone register (04). The high DTMF tones must be applied to the high-tone register, and the low DTMF tones to the low-tone register. The tone signals can be generated with three different resolutions at  $\Delta F = 7.8125$  Hz, 15.625 Hz, and 31.250 Hz. The resolution option can be selected by setting the register (06).

### analog mux

The analog switch can be used to source an analog signal to two different loads. The output can be reselected by setting the auxiliary register (06).

**detailed description (continued)**

**DTMF gain MUX**

The DTMF gain MUX selects the signal path and applies the appropriate gain setting. Therefore the device is either in tone mode or in voice mode. When set in the voice mode, the gain is controlled by the auxiliary register and is set to 0 dB or 6 dB. When set in the tone mode, the gain is from –12 dB to 12 dB in 6-dB steps which is set by the volume control register. The gain setting is controlled by the RXPGA register. This will not create any control contention since the device is working in one mode at a time.

**Terminal Functions**

TERMINAL†			I/O	DESCRIPTION
NAME	NO.			
	μBGA	TQFP		
AVDD	A1	32	I	Analog positive power supply
AVSS	J1	8	I	Analog negative power supply (use for ground connection)
BUZZCON	F9	19	O	Buzzer output, a pulse-density modulated signal to apply to external buzzer driver
DVDD	J6	13	I	Digital positive power supply
DVSS	J7	14	I	Digital negative power supply
EAR1ON	A6	27	O	Earphone 1 amplifier output (–)
EAR1OP	A4	29	O	Earphone 1 amplifier output (+)
EAR2O	A2	31	O	Earphone 2 amplifier output
EARVDD	A5	28	I	Analog positive power supply for the earphone amplifiers
EARVSS	A3, A7	30, 26	I	Analog negative power supply for the earphone amplifiers
MBIAS	B1	1	O	Microphone bias supply output, no decoupling capacitors
MCLK	C9	22	I	Master system clock input (2.048 MHz, digital)
MIC1P	C1	2	I	MIC1 input (+)
MIC1N	D1	3	I	MIC1 input (–)
MIC2P	E1	4	I	MIC2 input (+)
MIC2N	F1	5	I	MIC2 input (–)
MUXIN	H1	7	I	Analog MUX input
MUXOUT1	J2	9	I	Analog MUX output
MUXOUT2	J3	10	I	Analog MUX output
PCMI	J8	15	I	Receive PCM input
PCMO	J9	16	O	Transmit PCM output
PCMSYN	G9	18	I	PCM frame sync
PCMCLK	H9	17	I	PCM data clock
PLLVSS	A9	24	I	PLL negative power supply
PLLVDD	A8	25	I	PLL digital power supply
PWRUPSEL	E9	20	I	Selects the power-up default mode
REXT	G1	6	I/O	Internal reference current setting terminal (use precision 100-kΩ resistor and no filtering capacitors)
RESET	D9	21	I	Active low reset
SCL	J5	12	I	I <sup>2</sup> C-bus serial clock. This input is used to synchronize the data transfer from and to the PCM codec.
SDA	J4	11	I/O	I <sup>2</sup> C-bus serial address/data input/output. This is a bidirectional terminal used to transfer register control addresses and data into and out of the codec. It is an open-drain terminal and therefore requires a pullup resistor to VDD (typical 10 kΩ for 100 kHz).
VSS	B9	23	I	Ground return for bandgap internal reference (use for ground connection)

† All MicroStar Junior BGA™ pins that are not mentioned have no internal connection.

**absolute maximum ratings over operating free-air temperature range (unless otherwise noted)†**

Supply voltage range, $V_{DD}$ , $DV_{DD}$ , $PLL_{VDD}$ , $EAR_{VDD}$ .....	-0.5 V to 3.6 V
Output voltage range, $V_O$ .....	-0.5 V to 3.6 V
Input voltage range, $V_I$ .....	-0.5 V to 3.6 V
Continuous total power dissipation .....	See Dissipation Rating Table
Operating free air temperature range (industrial temperature) .....	-40°C to 85°C
Storage temperature range, testing .....	-65°C to 150°C
Lead temperature 1,6 mm from case for 10 seconds .....	260°C

† Stresses beyond those listed under “absolute maximum ratings” may cause permanent damage to the device. These are stress ratings only, and functional operation of the device at these or any other conditions beyond those indicated under “recommended operating conditions” is not implied. Exposure to absolute-maximum-rated conditions for extended periods may affect device reliability.

**DISSIPATION RATING TABLE**

PACKAGE	$T_A \leq 25^\circ\text{C}$ POWER RATING	DERATING FACTOR ABOVE $T_A = 25^\circ\text{C}$	$T_A = 85^\circ\text{C}$ POWER RATING	COMMENTS
TQFP	702 mW	7.2 mW/°C	270 mW	Low dissipation printed circuit board (PCB)
MicroStar Junior BGA	660 mW	164 mW/°C	220 mW	Low dissipation PCB
MicroStar Junior BGA	2.75 W	36 mW/°C	917 mW	High dissipation PCB

**recommended operating conditions (see Notes 1 and 2)**

	MIN	NOM	MAX	UNIT
Supply voltage, $V_{DD}$ , $DV_{DD}$ , $PLL_{VDD}$ , $EAR_{VDD}$	2.7		3.3	V
High-level input voltage, $V_{IH}$	$0.7 \times V_{DD}$			V
Low-level input voltage, $V_{IL}$			$0.3 \times V_{DD}$	V
Load impedance between EAR1OP and EAR1ON-RL		8 to 32		$\Omega$
Load impedance for EAR2OP-RL		32		$\Omega$
Operating free-air temperature, $T_A$	-40		85	°C

- NOTES: 1. To avoid possible damage and resulting reliability problems to these CMOS devices, follow the *power-on initialization* paragraph, described in the *Principles of Operation*.
2. Voltages are with respect to  $V_{SS}$ ,  $DV_{SS}$ ,  $PLL_{VSS}$ , and  $EAR_{VSS}$ .

**electrical characteristics over recommended ranges of supply voltage and free-air temperature (unless otherwise noted)****supply current**

PARAMETER	TEST CONDITIONS	MIN	TYP	MAX	UNIT
$I_{DD}$ Supply current from $V_{DD}$	Operating, EAR1 selected, MicBias disabled		4.5	6	mA
	Operating, EAR2 selected, MicBias disabled		4.5	6	mA
	Power down room temperature, $V_{DD} = 3$ V, Reg 6 bit 7 = 1, MCik not present (see Note 3)		2	10	$\mu\text{A}$
	Power down room temperature, $V_{DD} = 3$ V, , Reg 6 bit 7 = 0, MCik not present (see Note 3)		10	30	$\mu\text{A}$
$t_{on(i)}$ Power-up time from power down			5	10	ms

NOTE 3:  $V_{IHMIN} = V_{DD}$ ,  $V_{ILMAX} = V_{SS}$ .

**electrical characteristics over recommended ranges of supply voltage and free-air temperature (unless otherwise noted) (continued)**

**digital interface**

PARAMETER		TEST CONDITIONS	MIN	TYP	MAX	UNIT
V <sub>OH</sub>	High-level output voltage PCMO (BUZZCON)	I <sub>OH</sub> = -3.2 mA, V <sub>DD</sub> = 3 V	DV <sub>DD</sub> -0.25			V
V <sub>OL</sub>	Low-level output voltage PCMO	I <sub>OL</sub> = 3.2 mA, V <sub>DD</sub> = 3 V			0.25	V
I <sub>IH</sub>	High-level input current, any digital input	V <sub>I</sub> = V <sub>DD</sub>			10	μA
I <sub>IL</sub>	Low-level input current, any digital input	V <sub>I</sub> = V <sub>SS</sub>			10	μA
C <sub>i</sub>	Input capacitance				10	pF
C <sub>o</sub>	Output capacitance				20	pF
R <sub>L</sub>	Load impedance (BUZZCON)				5	kΩ

**microphone interface**

PARAMETER		TEST CONDITIONS	MIN	TYP	MAX	UNIT
V <sub>IO</sub>	Input offset voltage at MIC1N, MIC2N	See Note 4	-5		5	mV
I <sub>IB</sub>	Input bias current at MIC1N, MIC2N		-300		300	nA
C <sub>i</sub>	Input capacitance at MIC1N, MIC2N			5		pF
V <sub>n</sub>	Microphone input referred noise, psophometrically weighted, (C-message weighted is similar)	MIC amp 1 gain = 23.5 dB MIC amp 2 gain = 0 dB		3	4.7	μV <sub>rms</sub>
I <sub>Omax</sub>	Output source current—MBIAS		1		1.2	mA
V <sub>(mbias)</sub>	Microphone bias supply voltage (see Note 5)		2.3	2.5	2.65	V
	MICMUTE		-80			dB
	Input impedance	Fully differential	35	60	100	kΩ

NOTES: 4. Measured while MIC1P and MIC1N are connected together. Less than 0.5-mV offset results in 0 value code on PCMOUT.  
5. Not a JEDEC symbol.

electrical characteristics over recommended ranges of supply voltage and free-air temperature (unless otherwise noted) (continued)

### speaker interface

PARAMETER		TEST CONDITIONS	MIN	TYP	MAX	UNIT
Earphone AMP1 output power (see Note 6)		$V_{DD} = 2.7$ V, fully differential, 8- $\Omega$ load, 3-dBm0 output, volume control = -3 dB, RXPGA = -4 dB level		161	200	mW
		$V_{DD} = 2.7$ V, fully differential, 16- $\Omega$ load, 3-dBm0 output, volume control = -3 dB, RXPGA = -2 dB level		128	160	
		$V_{DD} = 2.7$ V, fully differential, 32- $\Omega$ load, 3-dBm0 output, volume control = -3 dB, RXPGA = -1 dB level		81	100	
Earphone AMP2 output power (see Note 6)		$V_{DD} = 2.7$ V, single-ended, 32- $\Omega$ load, 3-dBm0 output		10	12.5	mW
$V_{OO}$	Output offset voltage at EAR1	Fully differential		$\pm 5$	$\pm 30$	mV
$I_{Omax}$	Maximum output current for EAR1 (rms)	3-dBm0 input, 8- $\Omega$ load		141	178	mA
		3-dBm0 input, 16- $\Omega$ load		90	112	
		3-dBm0 input, 32- $\Omega$ load		50	63	
	Maximum output current for EAR2 (rms)	3-dBm0 input		17.7	22.1	
EARMUTE			-80			dB

NOTE 6: Maximum power is with a load impedance of -25%.

### transmit gain and dynamic range, companded mode ( $\mu$ -law or A-law) or linear mode selected, transmit slope filter bypassed (see Notes 7 and 8)

PARAMETER		TEST CONDITIONS	MIN	TYP	MAX	UNIT
Transmit reference-signal level (0 dB)		Differential			87.5	mV <sub>pp</sub>
Overload-signal level (3 dBm0)	Differential, normal mode				124	mV <sub>pp</sub>
	Differential, extended mode				31.5	
Absolute gain error		0-dBm0 input signal, $V_{DD} \pm 10\%$	-1		1	dB
Gain error with input level relative to gain at -10 dBm0 MIC1N, MIC1P to PCMO	MIC1N, MIC1P to PCMO at 3 dBm0 to -30 dBm0		-0.5		0.5	dB
	MIC1N, MIC1P to PCMO at -31 dBm0 to -45 dBm0		-1		1	
	MIC1N, MIC1P to PCMO at -46 dBm0 to -55 dBm0		-1.2		1.2	

NOTES: 7. Unless otherwise noted, the analog input is 0 dB, 1020-Hz sine wave, where 0 dB is defined as the zero-reference point of the channel under test.

8. The reference signal level, which is input to the transmit channel, is defined as a value 3 dB below the full-scale value of 88-mV<sub>rms</sub>.

### transmit gain and dynamic range, companded mode ( $\mu$ -law or A-law) or linear mode selected, transmit slope filter enabled (see Notes 7 and 8)

PARAMETER		TEST CONDITIONS	MIN	TYP	MAX	UNIT
Transmit reference-signal level (0 dB)		Differential			87.5	mV <sub>pp</sub>
Overload-signal level (3 dBm0)	Differential, normal mode				124	mV <sub>pp</sub>
	Differential, extended mode				31.5	
Absolute gain error		0-dBm0 input signal, $V_{DD} \pm 10\%$	-1		1	dB
Gain error with input level relative to gain at -10 dBm0 MIC1N, MIC1P to PCMO	MIC1N, MIC1P to PCMO at 3 dBm0 to -30 dBm0		-0.5		0.5	dB
	MIC1N, MIC1P to PCMO at -31 dBm0 to -45 dBm0		-1		1	
	MIC1N, MIC1P to PCMO at -46 dBm0 to -55 dBm0		-1.2		1.2	

NOTES: 7. Unless otherwise noted, the analog input is 0 dB, 1020-Hz sine wave, where 0 dB is defined as the zero-reference point of the channel under test.

8. The reference signal level, which is input to the transmit channel, is defined as a value 3 dB below the full-scale value of 88-mV<sub>rms</sub>.

electrical characteristics over recommended ranges of supply voltage and free-air temperature (unless otherwise noted) (continued)

transmit filter transfer, companded mode ( $\mu$ -law or A-law) or linear mode selected, transmit slope filter bypassed (MCLK = 2.048 MHz)

PARAMETER	TEST CONDITIONS	MIN	TYP	MAX	UNIT
Gain relative to input signal gain at 1020 Hz, internal high-pass filter disabled	$f_{MIC1}$ or $f_{MIC2} < 100$ Hz	-0.5		0.5	dB
	$f_{MIC1}$ or $f_{MIC2} = 200$ Hz	-0.5		0.5	
	$f_{MIC1}$ or $f_{MIC2} = 300$ Hz to 3 kHz	-0.5		0.5	
	$f_{MIC1}$ or $f_{MIC2} = 3.4$ kHz	-1.5		0	
	$f_{MIC1}$ or $f_{MIC2} = 4$ kHz			-14	
	$f_{MIC1}$ or $f_{MIC2} = 4.6$ kHz			-35	
	$f_{MIC1}$ or $f_{MIC2} = 8$ kHz			-47	
Gain relative to input signal gain at 1020 Hz, internal high-pass filter enabled	$f_{MIC1}$ or $f_{MIC2} < 100$ Hz			-15	dB
	$f_{MIC1}$ or $f_{MIC2} = 200$ Hz			-5	

transmit filter transfer, companded mode ( $\mu$ -law or A-law) or linear mode selected, transmit slope filter selected, transmit high-pass filter enabled (MCLK = 2.048 MHz) (see Note 9)

PARAMETER	TEST CONDITIONS	MIN	TYP	MAX	UNIT	
Gain relative to input signal gain at 1.02 kHz, with slope filter selected	$f_{MIC1}$ or $f_{MIC2} = 100$ Hz			-27	dB	
	$f_{MIC1}$ or $f_{MIC2} = 200$ Hz			-8	dB	
	$f_{MIC1}$ or $f_{MIC2} = 250$ Hz			-4	dB	
	$f_{MIC1}$ or $f_{MIC2} = 300$ Hz		-1.8		dB	
	$f_{MIC1}$ or $f_{MIC2} = 400$ Hz		-1.5		dB	
	$f_{MIC1}$ or $f_{MIC2} = 500$ Hz		-1.3		dB	
	$f_{MIC1}$ or $f_{MIC2} = 600$ Hz		-1.1		dB	
	$f_{MIC1}$ or $f_{MIC2} = 700$ Hz		-0.8		dB	
	$f_{MIC1}$ or $f_{MIC2} = 800$ Hz		-0.57		dB	
	$f_{MIC1}$ or $f_{MIC2} = 900$ Hz		-0.25		dB	
	$f_{MIC1}$ or $f_{MIC2} = 1000$ Hz		0		dB	
	$f_{MIC1}$ or $f_{MIC2} = 1500$ Hz		1.8		dB	
	$f_{MIC1}$ or $f_{MIC2} = 2000$ Hz		4.0		dB	
	$f_{MIC1}$ or $f_{MIC2} = 2500$ Hz		6.5		dB	
	$f_{MIC1}$ or $f_{MIC2} = 3000$ Hz		7.6		dB	
	$f_{MIC1}$ or $f_{MIC2} = 3100$ Hz		7.7		dB	
	$f_{MIC1}$ or $f_{MIC2} = 3300$ Hz		8		dB	
	$f_{MIC1}$ or $f_{MIC2} = 3500$ Hz		6.48		dB	
	$f_{MIC1}$ or $f_{MIC2} = 4000$ Hz				-13	dB
	$f_{MIC1}$ or $f_{MIC2} = 4500$ Hz				-35	dB
$f_{MIC1}$ or $f_{MIC2} = 5000$ Hz				-45	dB	
$f_{MIC1}$ or $f_{MIC2} = 8000$ Hz				-50	dB	

NOTE 9: The pass-band tolerance is  $\pm 0.25$  dB from 300 Hz to 3500 Hz.

electrical characteristics over recommended ranges of supply voltage and free-air temperature (unless otherwise noted) (continued)

transmit idle channel noise and distortion, companded mode ( $\mu$ -law or A-law) selected, slope filter bypassed

PARAMETER	TEST CONDITIONS	MIN	TYP	MAX	UNIT
Transmit idle channel noise, psophometrically weighted	TXPGA gain= 0 dB, MIC Amp 1 gain = 23.5 dB, MIC Amp 2 gain = 6 dB		-83.5	-78	dBm <sub>0p</sub>
Transmit signal-to-distortion ratio with 1020-Hz sine-wave input	MIC1N, MIC1P to PCMO at 3 dBm0		27		dBm0
	MIC1N, MIC1P to PCMO at 0 dBm0		30		
	MIC1N, MIC1P to PCMO at -5 dBm0		33		
	MIC1N, MIC1P to PCMO at -10 dBm0		36		
	MIC1N, MIC1P to PCMO at -20 dBm0		35		
	MIC1N, MIC1P to PCMO at -30 dBm0		26		
	MIC1N, MIC1P to PCMO at -40 dBm0		24		
Intermodulation distortion, 2-tone CCITT method, composite power level, -13 dBm0	CCITT G.712 (7.1), R2		49		dB
	CCITT G.712 (7.2), R2		51		

transmit idle channel noise and distortion, companded mode ( $\mu$ -law or A-law) selected, slope filter enabled

PARAMETER	TEST CONDITIONS	MIN	TYP	MAX	UNIT
Transmit idle channel noise, psophometrically weighted	TXPGA gain= 0 dB, MIC Amp 1 gain = 23.5 dB, MIC Amp 2 gain = 6 dB		-83.5	-78	dBm <sub>0p</sub>
Transmit signal-to-total distortion ratio with 1020-Hz sine-wave input	MIC1N, MIC1P to PCMO at 3 dBm0		27		dBm0
	MIC1N, MIC1P to PCMO at 0 dBm0		30		
	MIC1N, MIC1P to PCMO at -5 dBm0		33		
	MIC1N, MIC1P to PCMO at -10 dBm0		36		
	MIC1N, MIC1P to PCMO at -20 dBm0		35		
	MIC1N, MIC1P to PCMO at -30 dBm0		26		
	MIC1N, MIC1P to PCMO at -40 dBm0		24		
Intermodulation distortion, 2-tone CCITT method, composite power level, -13 dBm0	CCITT G.712 (7.1), R2		49		dB
	CCITT G.712 (7.2), R2		51		

transmit idle channel noise and distortion, linear mode selected, slope filter bypassed

PARAMETER	TEST CONDITIONS	MIN	TYP	MAX	UNIT
Transmit idle channel noise	TXPGA gain = 0 dB, MIC Amp 1 gain = 23.5 dB, MIC Amp 2 gain = 6 dB		-83.5	-78	dBm <sub>0p</sub>
Transmit signal-to-total distortion ratio with 1020-Hz sine-wave input	MIC1N, MIC1P to PCMO at 3 dBm0	50	50		dB
	MIC1N, MIC1P to PCMO at 0 dBm0	50	65		
	MIC1N, MIC1P to PCMO at -5 dBm0	52	61		
	MIC1N, MIC1P to PCMO at -10 dBm0	56	65		
	MIC1N, MIC1P to PCMO at -20 dBm0	50	59		
	MIC1N, MIC1P to PCMO at -30 dBm0	51	63		
	MIC1N, MIC1P to PCMO at -40 dBm0	43	55		
	MIC1N, MIC1P to PCMO at -45 dBm0	38	52		

electrical characteristics over recommended ranges of supply voltage and free-air temperature (unless otherwise noted) (continued)

transmit idle channel noise and distortion, linear mode selected, slope filter enabled

PARAMETER	TEST CONDITIONS	MIN	TYP	MAX	UNIT
Transmit idle channel noise	TXPGA gain = 0 dB, MIC Amp 1 gain = 23.5 dB, MIC Amp 2 gain = 6 dB		-83.5	-78	dBm <sub>0p</sub>
Transmit signal-to-total distortion ratio with 1020-Hz sine-wave input	MIC1N, MIC1P to PCMO at 3 dBm <sub>0</sub>	40	50		dB
	MIC1N, MIC1P to PCMO at 0 dBm <sub>0</sub>	50	65		
	MIC1N, MIC1P to PCMO at -5 dBm <sub>0</sub>	50	68		
	MIC1N, MIC1P to PCMO at -10 dBm <sub>0</sub>	64	70		
	MIC1N, MIC1P to PCMO at -20 dBm <sub>0</sub>	58	65		
	MIC1N, MIC1P to PCMO at -30 dBm <sub>0</sub>	50	60		
	MIC1N, MIC1P to PCMO at -40 dBm <sub>0</sub>	38	50		
	MIC1N, MIC1P to PCMO at -45 dBm <sub>0</sub>	30	45		

receive gain and dynamic range, EAR1 selected, linear or companded (μ-law or A-law) mode selected (see Note 10)

PARAMETER	TEST CONDITIONS	MIN	TYP	MAX	UNIT
Overload signal level (3 dB)	8-Ω load RXPGA = -4 dB		3.2		V <sub>pp</sub>
	16-Ω load RXPGA = -4 dB		4.05		
	32-Ω load RXPGA = -4 dB		4.54		
Absolute gain error	0 dBm <sub>0</sub> input signal, V <sub>DD</sub> ±10%	-1		1	dB
Gain error with output level relative to gain at -10 dBm <sub>0</sub>	PCMIN to EAR1ON, EAR1OP at 3 dBm <sub>0</sub> to -40 dBm <sub>0</sub>	-0.5		0.5	dB
	PCMIN to EAR1ON, EAR1OP at -41 dBm <sub>0</sub> to -50 dBm <sub>0</sub>	-1		1	
	PCMIN to EAR1ON, EAR1OP at -51 dBm <sub>0</sub> to -55 dBm <sub>0</sub>	-1.2		1.2	

NOTE 10: RXPGA = -4 dB for 32 Ω, 16 Ω, or 8 Ω, RXVOL = 0 dB, 1020-Hz input signal at PCMI, output measured differentially between EAR1ON and EAR1OP

receive gain and dynamic range, EAR2 selected, linear or companded (μ-law or A-law) mode selected (see Note 11)

PARAMETER	TEST CONDITIONS	MIN	TYP	MAX	UNIT
Receive reference signal level (0 dB)	0 dBm <sub>0</sub> PCM input signal		1.36		V <sub>pp</sub>
Overload-signal level (3 dB)			1.925		V <sub>pp</sub>
Absolute gain error	0 dBm <sub>0</sub> input signal, V <sub>DD</sub> ±10%	-1		1	dB
Gain error with output level relative to gain at -10 dBm <sub>0</sub>	PCMIN to EAR2O at 3 dBm <sub>0</sub> to -40 dBm <sub>0</sub>	-0.5		0.5	dB
	PCMIN to EAR2O at -41 dBm <sub>0</sub> to -50 dBm <sub>0</sub>	-1		1	
	PCMIN to EAR2O at -51 dBm <sub>0</sub> to -55 dBm <sub>0</sub>	-1.2		1.2	

NOTE 11: RXPGA = -1 dB, RXVOL = 0 dB

electrical characteristics over recommended ranges of supply voltage and free-air temperature (unless otherwise noted) (continued)

receive filter transfer, companded mode ( $\mu$ -law or A-law) or linear mode selected (MCLK = 2.048 MHz) (see Note 11)

PARAMETER	TEST CONDITIONS	MIN	TYP	MAX	UNIT
Gain relative to input signal gain at 1020 Hz, internal high-pass filter disabled	$f_{\text{EAR1}}$ or $f_{\text{EAR2}} < 100$ Hz	-0.5		0.5	dB
	$f_{\text{EAR1}}$ or $f_{\text{EAR2}} = 200$ Hz	-0.5		0.5	
	$f_{\text{EAR1}}$ or $f_{\text{EAR2}} = 300$ Hz to 3 kHz	-0.5		0.5	
	$f_{\text{EAR1}}$ or $f_{\text{EAR2}} = 3.4$ kHz	-1.5		0	
	$f_{\text{EAR1}}$ or $f_{\text{EAR2}} = 4$ kHz			-14	
	$f_{\text{EAR1}}$ or $f_{\text{EAR2}} = 4.6$ kHz			-35	
	$f_{\text{EAR1}}$ or $f_{\text{EAR2}} = 8$ kHz			-47	
Gain relative to input signal gain at 1020 Hz, internal high-pass filter enabled	$f_{\text{EAR1}}$ or $f_{\text{EAR2}} < 100$ Hz			-15	dB
	$f_{\text{EAR1}}$ or $f_{\text{EAR2}} = 200$ Hz			-5	

NOTE 11: RXPGA = -1 dB, RXVOL = 0 dB

receive idle channel noise and distortion, EAR1 selected, companded mode ( $\mu$ -law or A-law) selected (see Note 10)

PARAMETER	TEST CONDITIONS	MIN	TYP	MAX	UNIT
Receive noise, psophometrically weighted	PCMIN = 11010101 (A-law)		-89	-86	dBm <sub>0p</sub>
Receive noise, C-message weighted	PCMIN = 11111111 ( $\mu$ -law)		36	50	$\mu$ V <sub>rms</sub>
Receive signal-to-distortion ratio with 1020-Hz sine-wave input	PCMIN to EAR1ON, EAR1OP at 3 dBm <sub>0</sub>	21			dB
	PCMIN to EAR1ON, EAR1OP at 0 dBm <sub>0</sub>	25			
	PCMIN to EAR1ON, EAR1OP at -5 dBm <sub>0</sub>	36			
	PCMIN to EAR1ON, EAR1OP at -10 dBm <sub>0</sub>	43			
	PCMIN to EAR1ON, EAR1OP at -20 dBm <sub>0</sub>	40			
	PCMIN to EAR1ON, EAR1OP at -30 dBm <sub>0</sub>	38			
	PCMIN to EAR1ON, EAR1OP at -40 dBm <sub>0</sub>	28			
	PCMIN to EAR1ON, EAR1OP at -45 dBm <sub>0</sub>	23			

NOTE 10: RXPGA = -4 dB for 32  $\Omega$ , RXVOL = 0 dB, 1020-Hz input signal at PCMI, output measured differentially between EAR1ON and EAR1OP.

receive idle channel noise and distortion, EAR1 selected, linear mode selected (see Note 10)

PARAMETER	TEST CONDITIONS	MIN	TYP	MAX	UNIT
Receive noise, (20-Hz to 20-kHz brickwall window)	PCMIN = 0000000000000000		-88	-83	dBm <sub>0</sub>
Receive signal-to-distortion ratio with 1020-Hz sine-wave input	PCMIN to EAR1ON, EAR1OP at 3 dBm <sub>0</sub>	53	61		dB
	PCMIN to EAR1ON, EAR1OP at 0 dBm <sub>0</sub>	63	75		
	PCMIN to EAR1ON, EAR1OP at -5 dBm <sub>0</sub>	60	72		
	PCMIN to EAR1ON, EAR1OP at -10 dBm <sub>0</sub>	56	67		
	PCMIN to EAR1ON, EAR1OP at -20 dBm <sub>0</sub>	50	63		
	PCMIN to EAR1ON, EAR1OP at -30 dBm <sub>0</sub>	45	50		
	PCMIN to EAR1ON, EAR1OP at -40 dBm <sub>0</sub>	40	51		
Intermodulation distortion, 2-tone CCITT method, composite power level, -13 dBm <sub>0</sub>	CCITT G.712 (7.1), R2	50			dB
	CCITT G.712 (7.2), R2	54			

NOTE 10: RXPGA = -4 dB for 32  $\Omega$ , RXVOL = 0 dB, 1020-Hz input signal at PCMI, output measured differentially between EAR1ON and EAR1OP.

electrical characteristics over recommended ranges of supply voltage and free-air temperature (unless otherwise noted) (continued)

receive idle channel noise and distortion EAR2 selected, companded mode ( $\mu$ -law or A-law) selected (see Note 11)

PARAMETER	TEST CONDITIONS	MIN	TYP	MAX	UNIT
Receive noise, psophometrically weighted	PCMIN = 11010101 (A-law)		-82	-78	dBm <sub>op</sub>
Receive noise, C-message weighted	PCMIN = 11111111 ( $\mu$ -law)		36	50	$\mu$ V <sub>rms</sub>
Receive signal-to-distortion ratio with 1020-Hz sinewave input	PCMIN to EAR2O at 3 dBm0	21			dB
	PCMIN to EAR2O at 0 dBm0	25			
	PCMIN to EAR2O at -5 dBm0	36			
	PCMIN to EAR2O at -10 dBm0	43			
	PCMIN to EAR2O at -20 dBm0	40			
	PCMIN to EAR2O at -30 dBm0	38			
	PCMIN to EAR2O at -40 dBm0	28			
	PCMIN to EAR2O at -45 dBm0	23			

NOTE 11. RXPGA = -1 dB, RXVOL = 0 dB

receive idle channel noise and distortion, EAR2 selected, linear mode selected (see Note 11)

PARAMETER	TEST CONDITIONS	MIN	TYP	MAX	UNIT
Receive noise, (20-Hz to 20-kHz brickwall window)	PCMIN = 0000000000000000		-83	-86	dBm0
Receive signal-to-noise + distortion ratio with 1020-Hz sinewave input	PCMIN to EAR2O at 3 dBm0	53	60		dB
	PCMIN to EAR2O at 0 dBm0	60	65		
	PCMIN to EAR2O at -5 dBm0	58	62		
	PCMIN to EAR2O at -10 dBm0	55	60		
	PCMIN to EAR2O at -20 dBm0	53	60		
	PCMIN to EAR2O at -30 dBm0	51	58		
	PCMIN to EAR2O at -40 dBm0	50	57		
Intermodulation distortion, 2-tone CCITT method	CCITT G.712 (7.1), R2	50			dB
	CCITT G.712 (7.2), R2	54			

NOTE 11: RXPGA = -1 dB, RXVOL = 0 dB

power supply rejection and crosstalk attenuation

PARAMETER	TEST CONDITIONS	MIN	TYP	MAX	UNIT
Supply voltage rejection, transmit channel	MIC1N, MIC1P = 0 V, V <sub>DD</sub> = 3 V <sub>dc</sub> + 100 mV <sub>peak to peak</sub> , f = 0 to 50 kHz		-86	-70	dB
Supply voltage rejection, receive channel, EAR1 selected (differential)	PCM code = positive zero, V <sub>DD</sub> = 3 V <sub>dc</sub> + 100 mV <sub>peak to peak</sub> , f = 0 to 50 kHz		-98	-70	dB
Crosstalk attenuation, transmit-to-receive (differential)	MIC1N, MIC1P = 0 dB, f = 300 to 3400 Hz measured differentially between EAR1ON and EAR1OP	70			dB
Crosstalk attenuation, receive-to-transmit	PCMIN = 0 dBm0, f = 300 to 3400 Hz measured at PCMO, EAR1 amplifier	70			dB

**timing requirements****clock (2.048-MHz CLK)**

PARAMETER		MIN	NOM	MAX	UNIT
$t_t$	Transition time, MCLK			10	ns
$f_{(mclk)}$	MCLK frequency		2.048		MHz
	MCLK jitter			37%	
	Number of PCMCLK clock cycles per PCMSYN frame	256		256	cycles
$t_c(PCMCLK)$	PCMCLK clock period	156	488	512	ns
	Duty cycle, PCMCLK	45%	50%	68%	

**transmit (2.048-MHz CLK) (see Figure 1)**

PARAMETER		MIN	MAX	UNIT
$t_{su}(PCMSYN)$	Setup time, PCMSYN high before falling edge of PCMCLK	20	$t_c(PCMCLK)-20$	ns
$t_h(PCMSYN)$	Hold time, PCMSYN high after falling edge of PCMCLK	20	$t_c(PCMCLK)-20$	

**receive (2.048-MHz CLK) (see Figure 2)**

PARAMETER		MIN	MAX	UNIT
$t_{su}(PCSYN)$	Setup time, PCMSYN high before falling edge of PCMCLK	20	$t_c(PCMCLK)-20$	ns
$t_h(PCSYN)$	Hold time, PCMSYN high after falling edge of PCMCLK	20	$t_c(PCMCLK)-20$	ns
$t_{su}(PCMI)$	Setup time, PCMI high or low before falling edge of PCMCLK	20		ns
$t_h(PCMI)$	Hold time, PCMI high or low after falling edge of PCMCLK	20		ns

**clock (128-kHz CLK)**

PARAMETER		MIN	NOM	MAX	UNIT
$t_t$	Transition time, MCLK			10	ns
$f_{(mclk)}$	MCLK frequency		128		kHz
	MCLK jitter			5%	
	Number of PCMCLK clock cycles per PCMSYN frame	16		16	
$t_c(PCMCLK)$	PCMCLK clock period	742.19	781.25	820.31	ns
	Duty cycle, PCMCLK	40%	50%	60%	
$t_c(PCMSYN)$	PCMSYN clock period		125		$\mu$ s
	Duty cycle, PCMSYN	49.5%	50%	50.5%	

**transmit (128-kHz CLK) (see Figure 5)**

PARAMETER		MIN	MAX	UNIT
$t_{su}(PCMSYN)$	Setup time, PCMSYN high before PCMCLK $\uparrow$	20	$t_c(PCMCLK)/4$	ns
$t_h(PCMSYN)$	Hold time, PCMSYN high after PCMCLK $\downarrow$	20	$t_c(PCMCLK)/4$	
$t_v(PCMO)$	Data valid time after the rising edge of PCMSYN	50		ns

**receive (128-kHz CLK) (see Figure 4)**

PARAMETER		MIN	MAX	UNIT
$t_{su}(PCSYN)$	Setup time, PCMSYN high before rising edge of PCMCLK	20	$t_c(PCMCLK)/4$	ns
$t_h(PCSYN)$	Hold time, PCMSYN high after falling edge of PCMCLK	20	$t_c(PCMCLK)/4$	ns
$t_{su}(PCMI)$	Setup time, PCMI high or low before falling edge of PCMCLK	20		ns
$t_h(PCMI)$	Hold time, PCMI high or low after falling edge of PCMCLK	20		ns

**timing requirements (continued)**

**I<sup>2</sup>C bus timing requirements (see Figure 3)**

PARAMETER		MIN	MAX	UNIT
SCL	Clock frequency		400	kHz
t <sub>w</sub> (SCLH)	Pulse duration, SCL high	600		ns
t <sub>w</sub> (SCLL)	Pulse duration, SCL low	1300		ns
t <sub>h</sub> (STA)	Hold time, SCL high after SDA↓ (repeated START condition)†	600		ns
t <sub>su</sub> (STA)	Setup time, for SCL high before SDA↓ repeated START condition	600		ns
t <sub>h</sub> (DAT)	Hold time, SDA valid after SCL low	0		ns
t <sub>su</sub> (DAT)	Setup time, SDA valid before SCL↑	100		ns
t <sub>su</sub> (STO)	Setup time, STOP condition	600		ns
t <sub>w</sub> (SDAT)	Pulse duration, SDA high (bus free time)	1300		ns
t <sub>r</sub>	Rise time (SDA and SCL)		300	ns
t <sub>f</sub>	Fall time (SDA and SCL)		300	ns

† After this period, the first block pulse is generated.

**switching characteristics over recommended ranges of supply voltages and operating free-air temperature**

**propagation delay times, C<sub>L(max)</sub> = 10 pF (see Figure 1)**

PARAMETER		MIN	MAX	UNIT
t <sub>pd1</sub>	PCMCLK bit 1 high to PCMO bit 1 valid		35	ns
t <sub>pd2</sub>	PCMCLK high to PCMO valid, bits 2 to n		35	ns
t <sub>pd3</sub>	PCMCLK bit n low to PCMO bit n Hi-Z	30		ns

**DTMF generator**

PARAMETER	TEST CONDITIONS	MIN	TYP	MAX	UNIT
DTMF high to low tone relative amplitude (preemphasis)		1.5	2	2.5	dB
Tone frequency accuracy (for DTMF)	Resolution of 7.8125 Hz	-1.5%		1.5%	
Harmonic distortion	Measured from lower tone group to highest parasitic			-20	dB

**MICBIAS**

PARAMETER	TEST CONDITIONS	MIN	TYP	MAX	UNIT
Load impedance (bias mode)			5		kΩ

PARAMETER MEASUREMENT INFORMATION

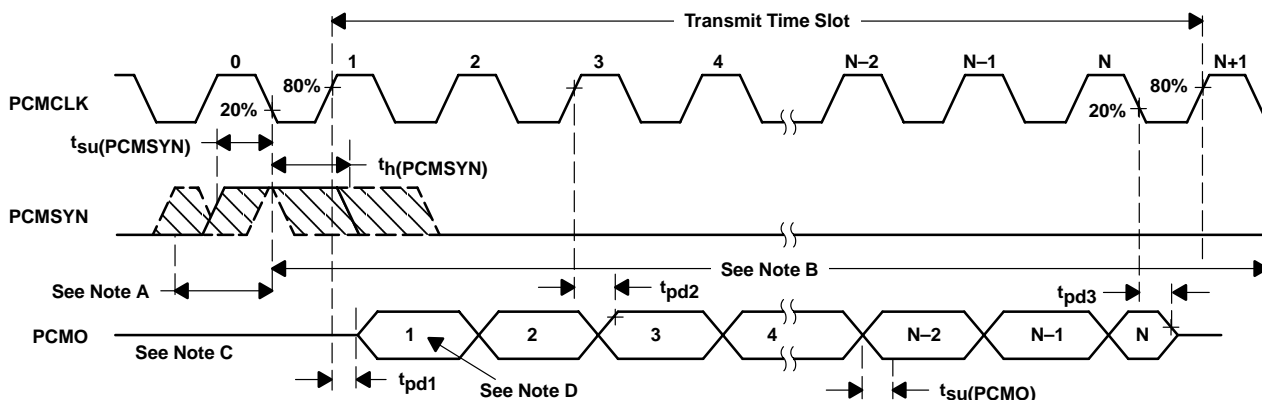

- NOTES: A. This window is allowed for PCMSYN high.  
 B. This window is allowed for PCMSYN low ( $t_h(PCMSYN)$  max determined by data collision considerations).  
 C. Transitions are measured at 50%.  
 D. Bit 1 = MSB, Bit N = LSB

Figure 1. Transmit Timing Diagram (2.048 MHz)

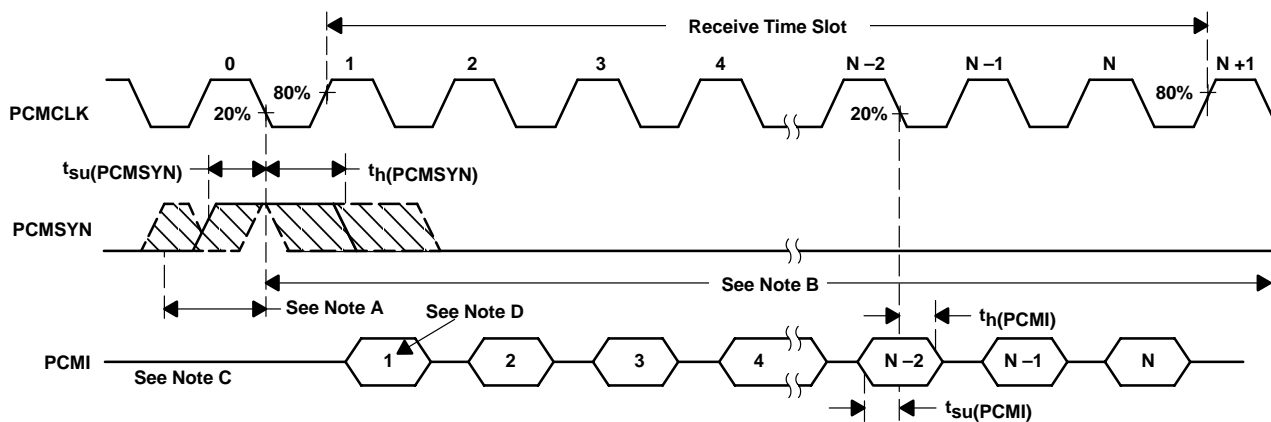

- NOTES: A. This window is allowed for PCMSYN high.  
 B. This window is allowed for PCMSYN low.  
 C. Transitions are measured at 50%.  
 D. Bit 1 = MSB, Bit N = LSB

Figure 2. Receive Timing Diagram (2.048 MHz)

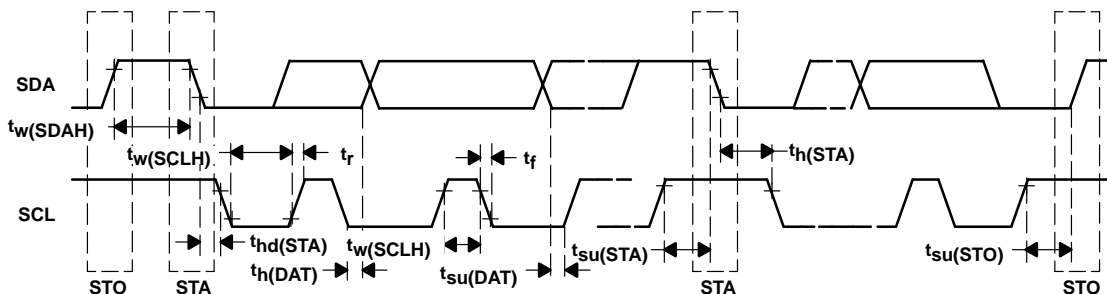

Figure 3. I<sup>2</sup>C-Bus Timing Diagram

PARAMETER MEASUREMENT INFORMATION

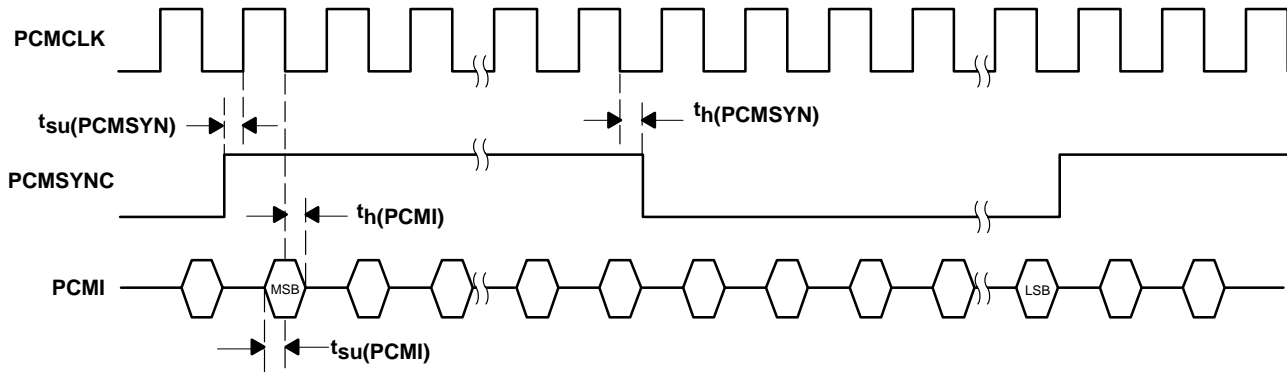

Figure 4. Receive Timing Diagram, 128 kHz

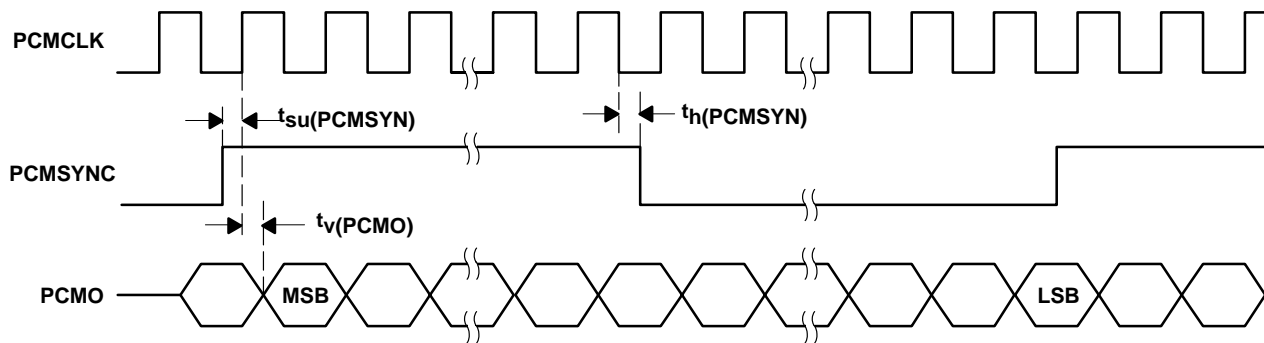

Figure 5. Transmit Timing Diagram, 128 kHz

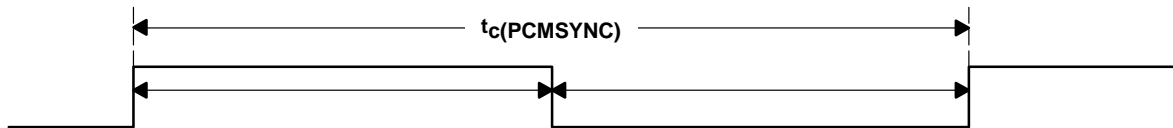
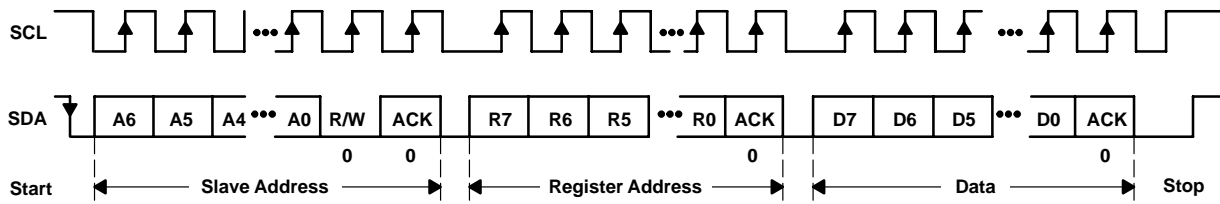

Figure 6. PCMSYNC Timing, 128 kHz

PARAMETER MEASUREMENT INFORMATION



NOTE: SLAVE = Voice Codec

Figure 7. I<sup>2</sup>C-Bus Write to Voice Codec

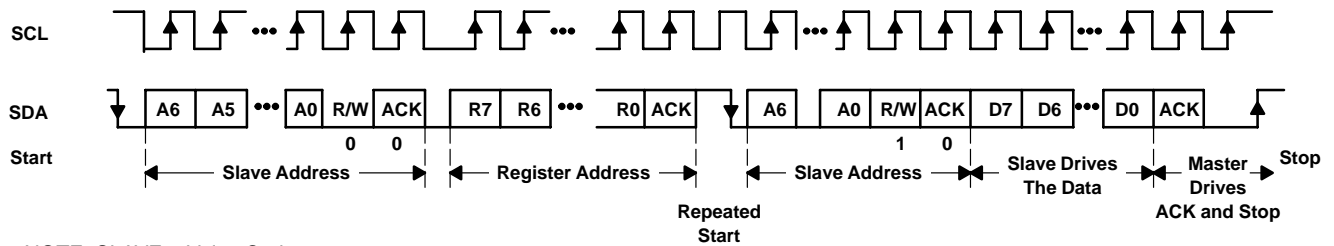

NOTE: SLAVE = Voice Codec

Figure 8. I<sup>2</sup>C Read From Voice Codec: Protocol A

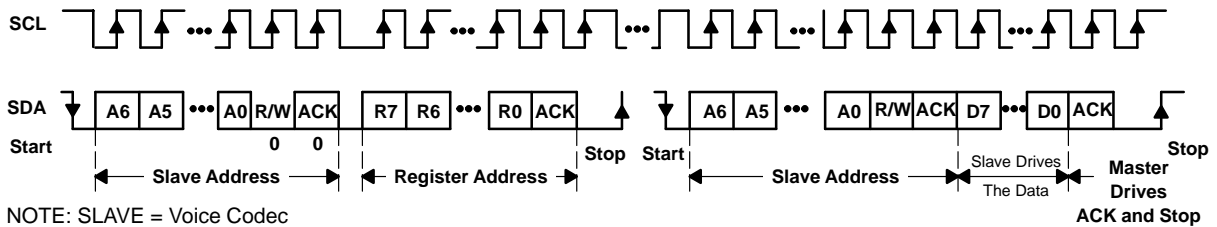

NOTE: SLAVE = Voice Codec

Figure 9. I<sup>2</sup>C Read From Voice Codec: Protocol B

TYPICAL CHARACTERISTICS

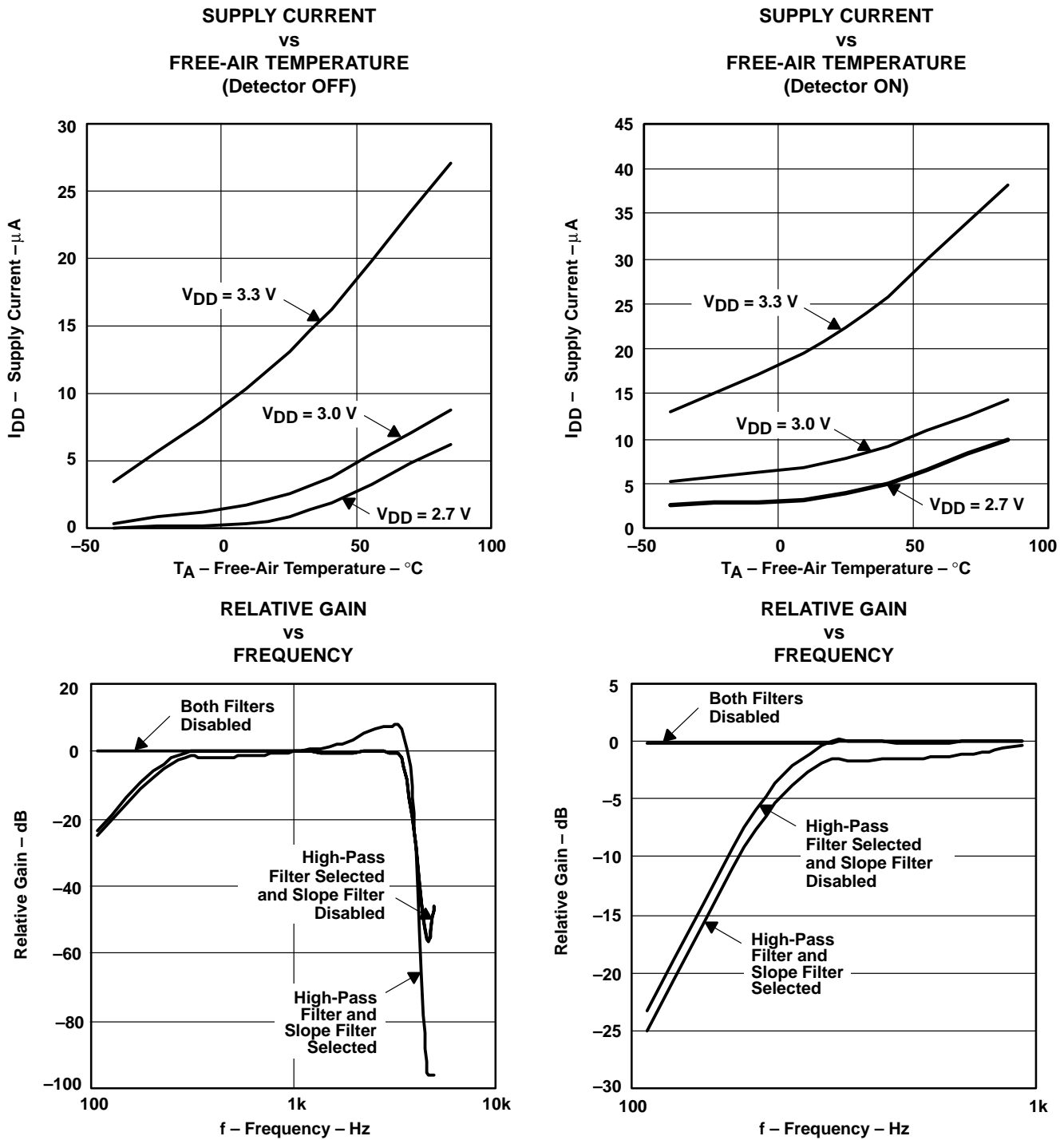
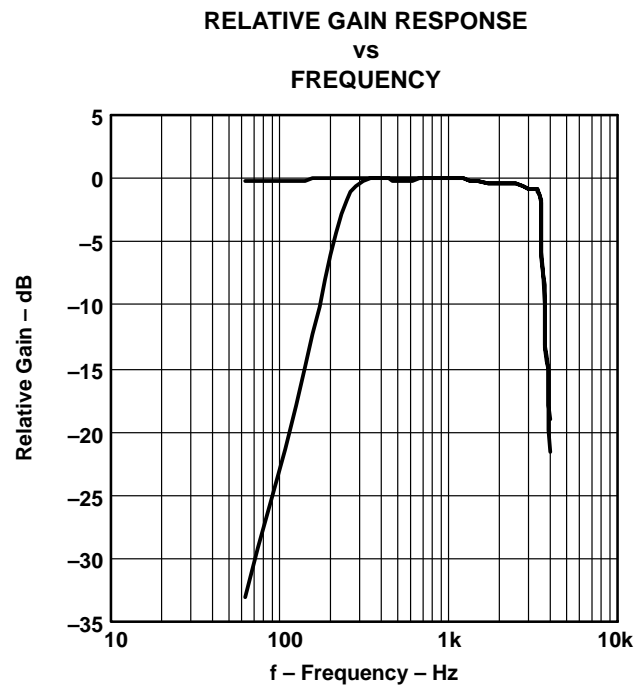

Figure 10. Transmit Gain Response With Respect to Gain of 1-kHz Tone

## TYPICAL CHARACTERISTICS



**Figure 11. Receive Gain Response With Respect to Gain of 1-kHz Tone  
With High-Pass Filter Selected and High-Pass Filter Disabled**

**PRINCIPLES OF OPERATION**

**power-on initialization**

An external reset with a minimum pulse width of 500 ns must be applied to the active low  $\overline{\text{RESET}}$  terminal to assure reset upon power on. All registers are set with default values upon external reset initialization.

The desired selection for all programmable functions can be initialized prior to a power-up command using the control interface.

**Table 1. Power-Up and Power-Down Procedures ( $V_{DD} = 2.7 \text{ V}$ , earphone amplifier unloaded)**

DEVICE STATUS	PROCEDURE	MAXIMUM POWER CONSUMPTION
Power up	Set bit 1 = 1 in power control register, EAR1 enabled	16.2 mW
	Set bit 1 = 0 in power control register, EAR2 enabled	14.6 mW
Power down	Set bit 7 = 1 in TXPGA control register and bit 0 = 0	1.35 $\mu\text{W}$
	Set bit 7 = 0 in TXPGA control register and bit 0 = 0	67.5 $\mu\text{W}$

In addition to resetting the power down bit in the power control register, loss of MCLK (no transition detected) automatically enters the device into a power-down state with PCMO in the high impedance state. If during a pulse code modulation (PCM) data transmit cycle an asynchronous power down occurs, the PCM interface remains powered up until the PCM data is completely transferred.

An additional power-down mode overrides the MCLK detection function. This allows the device to enter the power down state without regard to MCLK. Setting bit 7 of the TXPGA sidetone register to logic high enables this function.

**internal reference current setting terminal**

Use a 100-k $\Omega$  precision resistor to connect the REXT pin to GND.

**conversion laws**

The device can be programmed for either a 15-bit linear or and 8-bit ( $\mu$ -law or A-law) companding mode. The companding operation approximates the CCITT G.711 recommendation. The linear mode operation uses a 15-bit twos-complement format.

**transmit operation**

**microphone input**

The microphone input stage is a low-noise differential amplifier that provides a preamplifier gain of 23.5 dB. It is recommended that a microphone capacitively connected to the MIC1N and MIC1P inputs, while the MIC2N and MIC2P inputs can be used to capacitively connect a second microphone or an auxiliary audio circuit.

PRINCIPLES OF OPERATION

transmit operation (continued)

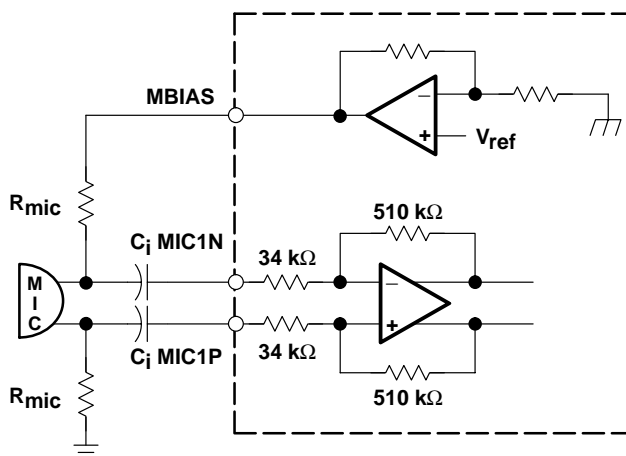

Figure 12. Typical Microphone Interface

microphone mute function

Transmit channel muting provides 80-dB attenuation of the input microphone signal. The MICMUTE function can be selected by setting bit 6 of the power control register through the I<sup>2</sup>C interface.

transmit channel gain control

The values in the transmit PGA control registers control the gain in the transmit path. The total TX channel gain can vary from 41.5 dB to 19.5 dB. The default total TX channel gain is 23.5 dB.

Table 2. Transmit Gain Control

BIT NAME				MIC AMP1	MIC AMP2	TX PGA	GAIN MODE	TOTAL TX GAIN			
TP3	TP2	TP1	TP0	GAIN	GAIN	GAIN		MIN	TYP	MAX	UNIT
0	0	0	0	23.5	18	0	Extended	41.3	41.5	41.7	dB
0	0	0	1	23.5	18	-2	Extended	39.3	39.5	39.7	dB
0	0	1	0	23.5	18	-4	Extended	37.3	37.5	37.7	dB
0	0	1	1	23.5	18	-6	Extended	35.3	35.5	35.7	dB
0	1	0	0	23.5	18	-8	Extended	33.3	33.5	33.7	dB
0	1	0	1	23.5	18	-10	Extended	31.3	31.5	31.7	dB
1	0	0	0	23.5	6	0	Normal	29.3	29.5	29.7	dB
1	0	0	1	23.5	6	-2	Normal	27.3	27.5	27.7	dB
1	0	1	0	23.5	6	-4	Normal	25.3	25.5	25.7	dB
1	0	1	1	23.5	6	-6	Normal	23.3	23.5	23.7	dB
1	1	0	0	23.5	6	-8	Normal	21.3	21.5	21.7	dB
1	1	0	1	23.5	6	-10	Normal	19.3	19.5	19.7	dB

**PRINCIPLES OF OPERATION**

**receive operation**

**receive channel gain control**

The values in the receive PGA control registers control the gain in the receive path. PGA gain is set from –6 dB to 6 dB in 1-dB steps through the I<sup>2</sup>C interface. The default receive channel gain is –4 dB.

**Table 3. Receive PGA Gain Control**

BIT NAME				RELATIVE GAIN, VOICE MODE				DTMF GAIN, TONE NODE
RP3	RP2	RP1	RP0	MIN	TYP	MAX	UNIT	
0	0	0	0	5.8	6	6.2	dB	12
0	0	0	1	4.8	5	5.2	dB	12
0	0	1	0	3.8	4	4.2	dB	12
0	0	1	1	2.8	3	3.2	dB	6
0	1	0	0	1.8	2	2.2	dB	6
0	1	0	1	0.8	1	1.2	dB	6
0	1	1	0	-0.2	0	0.2	dB	0
0	1	1	1	-1.2	-1	-0.8	dB	0
1	0	0	0	-2.2	-2	-1.8	dB	0
1	0	0	1	-3.2	-3	-2.8	dB	-6
1	0	1	0	-4.2	-4	-3.8	dB	-6
1	0	1	1	-5.2	-5	-4.8	dB	-6
1	1	0	0	-6.2	-6	-5.8	dB	-12
1	1	0	1		X		dB	-12
1	1	1	0		X		dB	-12

**sidetone gain control**

The values in the sidetone PGA control registers control the sidetone gain. Sidetone gain is set from –12 dB to –24 dB in 2-dB steps through the I<sup>2</sup>C interface. Sidetone can be muted by setting bit 7 of the power control register. The default sidetone gain is –12 dB.

**Table 4. Sidetone Gain Control**

BIT NAME			RELATIVE GAIN			
ST2	ST1	ST0	MIN	TYP	MAX	UNIT
0	0	0	-12.2	-12	-11.8	dB
0	0	1	-14.2	-14	-13.8	dB
0	1	0	-16.2	-16	-15.8	dB
0	1	1	-18.2	-18	-17.8	dB
1	0	0	-20.2	-20	-19.8	dB
1	0	1	-22.2	-22	-21.8	dB
1	1	0	-24.2	-24	-23.8	dB

---

**PRINCIPLES OF OPERATION**
**receive operation (continued)****receive volume control**

The values in the volume control PGA control registers provide volume control for the earphone. Volume control gain is set from 0 dB to –18 dB in 2-dB steps through the I<sup>2</sup>C interface. The default RX volume control gain is 0 dB.

**Table 5. RX Volume Control**

BIT NAME				RELATIVE GAIN			UNIT
RV3	RV2	RV1	RV0	MIN	TYP	MAX	
0	0	0	0	–0.2	0	0.2	dB
0	0	0	1	–2.2	–2	–1.8	dB
0	0	1	0	–4.2	–4	–3.8	dB
0	0	1	1	–6.2	–6	–5.8	dB
0	1	0	0	–8.2	–8	–7.8	dB
0	1	0	1	–10.2	–10	–9.8	dB
0	1	1	0	–12.2	–12	–11.8	dB
0	1	1	1	–14.2	–14	–13.8	dB
1	0	0	0	–16.2	–16	–15.8	dB
1	0	0	1	–18.2	–18	–17.8	dB

**earphone amplifier**

The analog signal can be routed to either of two earphone amplifiers: one with a differential output (EAR1ON and EAR1OP) capable of driving a 8-Ω load, or one with a single-ended output (EAR2O) capable of driving a 8-Ω load.

**earphone mute function**

Muting can be selected by setting bit 3 of the power control register through the I<sup>2</sup>C interface.

**receive PCM data format**

- Companded mode: 8 bits are received, the most significant (MSB) first.
- Linear mode: 15 bits are received, MSB first.

**PRINCIPLES OF OPERATION**

**receive operation (continued)**

**Table 6. Receive-Data Bit Definitions**

BIT NO.	COMPANDED MODE	LINEAR MODE
1	CD7	LD14
2	CD6	LD13
3	CD5	LD12
4	CD4	LD11
5	CD3	LD10
6	CD2	LD9
7	CD1	LD8
8	CD0	LD7
9	–	LD6
10	–	LD5
11	–	LD4
12	–	LD3
13	–	LD2
14	–	LD1
15	–	LD0
16	–	—

Transmit channel gain control bits always follow the PCM data in time:

CD7-CD0 = data word in companded mode

LD14-LD0 = data word in linear mode

**DTMF generator operation and interface**

The DTMF circuit generates the summed DTMF tones for push button dialing and provides the PDM output for the BUZZCON user-alert tone. The integer value is determined by the formula round tone [Freq (Hz)/resolution (Hz)]. The integer value is loaded into one of two 8-bit registers, high-tone register (04) or low-tone register (05). The tone output is 2 dB higher when applied to the high-tone register (04). When generating DTMF tones, the high-frequency value must be applied to the high tone register (04) and the low DTMF value to the low-tone register.

The DTMF frequency resolution is controlled by the auxiliary register (06) bits 2, 3, 4, and 5. When the resolution is set to 7.8125 Hz, the frequency range can be up to 1992.2 Hz. A wider range can be accomplished (for example, 2x or 4x) by selecting lower resolutions of 15.625 Hz or 31.250 Hz. The gain setting is controlled by the RXPGA gain control. This register applies the required gain to obtain MUX control during tone mode operation. Table 3 shows the relationship of the two gain settings.

---

**PRINCIPLES OF OPERATION**
**DTMF generator operation and interface (continued)****Table 7. Typical DTMF and Single Tone Control**

DT7	DT6	DT5	DT4	DT3	DT2	DT1	DT0	INTEGER VALUE	TONE FUNCTION	TONE/Hz
0	1	0	1	1	0	0	1	89	DTMF Low	697
0	1	1	0	0	0	1	1	99	DTMF Low	770
0	1	1	0	1	1	0	1	109	DTMF Low	852
0	1	1	1	1	0	0	0	120	DTMF Low	941
1	0	0	1	1	0	1	1	155	DTMF High	1209
1	0	1	0	1	0	1	1	171	DTMF High	1336
1	0	1	1	1	1	0	1	189	DTMF High	1477
1	1	0	1	0	0	0	1	209	DTMF High	1633

Tones from the DTMF generator block are present at all outputs and are controlled by enabling or disabling the individual output ports. The values that determine the tone frequency are loaded into the tone registers (high and low) as two separate values.

The values loaded into the tone registers initiate an iterative table look-up function, placing a 6-bit or 7-bit in twos-complement value into the the tone registers. There is a 2-dB difference in the resulting output of the two registers, the high-tone register having the greater result.

In the case of low-tone signal, the tone generator outputs a 6-bit integer with a maximum code of 31 (011111). However, the DTMF output is an 8-bit integer. Therefore, two zeros are padded to the MSB position, which results in 31 (00011111). On the other hand, the receive channel requires a 15-bit integer, the input 3968 (000111110000000). Since the maximum digital value of receive channel is 16383 (011111111111111), the maximum low-tone signal is designed to be –12.32 dB below the full digital scale.

$$20 \log \left( \frac{3968}{16383} \right)^2 = -12.32 \text{ dB} \quad (1)$$

In the case of high-tone signal, the tone generator outputs a 7-bit integer with a maximum code of 39 (0100111). The DTMF, therefore, pads a zero to the MSB and generates an 8-bit integer (00100111). In order to send the digital code to receive channel, it is converted to a 15-bit integer with seven more zeros padded to LSB position and biased as 4992 (001001110000000). Therefore, the maximum high-tone signal is designed to be –10.32 dB below the full digital scale.

$$20 \log \left( \frac{4992}{16383} \right)^2 = -10.32 \text{ dB} \quad (2)$$

In the case of DTMF output, the tone generator outputs an 8-bit integer with the maximum code level of 70 (01000110). This output is converted to a 15-bit code with the value of 8960 (010001100000000). Therefore, the maximum output of DTMF is designed to be –5.24 dB below the full digital scale.

$$20 \log \left( \frac{8960}{16383} \right)^2 = -5.24 \text{ dB} \quad (3)$$

**PRINCIPLES OF OPERATION**

**buzzer logic section**

The single-ended output BUZZCON is a PDM signal intended to drive a buzzer through an external driver transistor. The PDM begins as a selected DTMF tone, generated and passed through the receive D/A channel and fed back to the transmit channel analog modulator, where a PDM signal is generated and routed to the BUZZCON output.

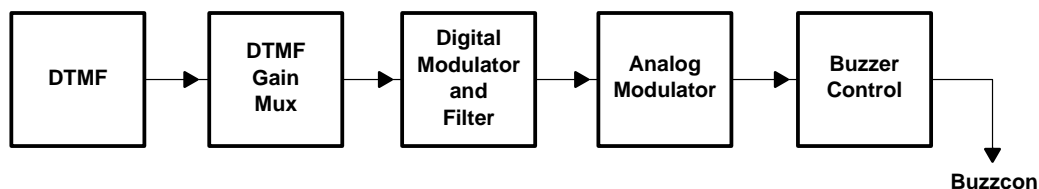

**Figure 13. Buzzer Driver System Architecture**

**support section**

The clock generator and control circuit use the master clock input (MCLK) to generate internal clocks to drive internal counters, filters, and convertors. Register control data is written into and read back from the PCM codec registers via the control interface.

**I<sup>2</sup>C-bus protocols**

The PCM codec serial interface is designed to be I<sup>2</sup>C bus-compatible and operates in the slave mode when CE is high. This interface consists of the following terminals:

- SCL: I<sup>2</sup>C-bus serial clock. This input synchronizes the control data transfer to and from the codec.
- SDA: I<sup>2</sup>C-bus serial address/data input/output. This is a bidirectional terminal that transfers register control addresses and data into and out of the codec. It is an open drain terminal and therefore requires a pullup resistor to V<sub>CC</sub> (typical 10 kΩ for 100 kHz).

TLV320AIC1110 has a fixed device select address of (E2)HEX for write mode and (E3)HEX for read mode.

For normal data transfer, SDA is allowed to change only when SCL is low. Changes when SCL is high are reserved for indicating the start and stop conditions.

Data transfer may be initiated only when the bus is not busy. During data transfer, the data line must remain stable whenever the clock line is at high. Changes in the data line while the clock line is at high are interpreted as a start or stop condition.

**Table 8. I<sup>2</sup>C-Bus Conditions**

CONDITION	STATUS	DESCRIPTION
A	Bus not busy	Both data and clock lines remain at high.
B	Start data transfer	A high to low transition of the SDA line while the clock (SCL) is high determines a start condition. All commands must proceed from a start condition.
C	Stop data transfer	A low to high transition of the SDA line while the clock (SCL) is high determines a stop condition. All operations must end with a stop condition.
D	Data valid	The state of the data line represents valid data when, after a start condition, the data line is stable for the duration of the high period of the clock signal.

The data on the line must be changed during the low period of the clock signal. There is one clock pulse per bit of data.

## PRINCIPLES OF OPERATION

### I<sup>2</sup>C-bus protocols (continued)

Each data transfer is initiated with a start condition and terminated with a stop condition. The number of data bytes, transferred between the start and stop conditions, is determined by the master device (microprocessor).

When addressed, the PCM codec generates an acknowledge after the reception of each byte. The master device must generate an extra clock pulse that is associated with this acknowledge bit.

The PCM codec must pull down the SDA line during the acknowledge clock pulse so that the SDA line is at stable low state during the high period of the acknowledge related clock pulse. Setup and hold times must be taken into account. During read operations, the master device must signal an end of data to the slave by not generating an acknowledge bit on the last byte that was clocked out of the slave. In this case, the slave (PCM codec) must leave the data line high to enable the master device to generate the stop condition.

### clock frequencies and sample rates

A fixed PCMSYN rate of 8 kHz determines the sampling rate.

### register map addressing

	REG	BITS							
		07	06	05	04	03	02	01	00
Power control	00	Sidetone En	TXEn	RX TX En	MICSEL	BIASEn	RXEn	EAROUT Sel	PWRUP
Mode control	01	Comp Sel	TMEEn	PCMLB	Comp En	BUZZEn	RXFLTR En	TXFLTR En	TXSLOPE En
TXPGA	02	X	TP3	TP2	TP1	TP0	ST2	ST1	ST0
RXPGA	03	RP3	RP2	RP1	RP0	RV3	RV2	RV1	RV0
High DTMF	04	HIFREQ Sel7	HIFREQ Sel6	HIFREQ Sel5	HIFREQ Sel4	HIFREQ Sel3	HIFREQ Sel2	HIFREQ Sel1	HIFREQ Sel0
Low DTMF	05	LOFREQ Sel7	LOFREQ Sel6	LOFREQ Sel5	LOFREQ Sel4	LOFREQ Sel3	LOFREQ Sel2	LOFREQ Sel1	LOFREQ Sel0
AUX	06	MCLK Detect	RXPGA2†	DTMFH1	DTMFH0	DTML1	DTMFL0	AMVX	MCLK sel

† For voice mode only

### register power-up defaults

	REG	BITS							
		07	06	05	04	03	02	01	00
Power control (1)†	00	1	1	1	1	0	1	1	0
Power control (2)‡	00	1	0	0	1	1	0	1	1
Mode control	01	0	0	0	0	0	0	1	0
TXPGA	02	0	1	0	0	0	0	0	0
RXPGA	03	1	0	1	0	0	0	0	0
High DTMF	04	0	0	0	0	0	0	0	0
Low DTMF	05	0	0	0	0	0	0	0	0
AUX	06	0	0	0	0	0	0	0	0

† 1. Value when PWRUPSEL = 0

‡ 2. Value when PWRUPSEL = 1

PRINCIPLES OF OPERATION

register map

Table 9. Power Control Register: Address (00) HEX

BIT NUMBER								DEFINITIONS
7	6	5	4	3	2	1	0	
1	1	1	1	0	1	1	0	Default setting PWRUPSEL = 0
1	0	0	1	1	0	1	1	Default setting PWRUPSEL = 1
X	X	X	X	X	X	X	0	Reference system, power down
X	X	X	X	X	X	X	1	Reference system, power up
X	X	X	X	X	X	1	X	EAR AMP1 selected, EAR AMP2 power down
X	X	X	X	X	X	0	X	EAR AMP2 selected, EAR AMP1 power down
X	X	X	X	X	0	X	X	Receive channel enabled
X	X	0	X	X	1	X	X	Receive channel muted
X	X	1	X	X	1	X	0	Receive channel, power down
X	X	X	X	1	X	X	X	Micbias enable
X	X	X	X	0	X	X	X	Micbias disable
X	X	X	1	X	X	X	X	MIC1 selected
X	X	X	0	X	X	X	X	MIC2 selected
X	0	X	X	X	X	X	X	Transmit channel enabled
X	1	0	X	X	X	X	X	Transmit channel muted
X	1	1	X	X	X	X	X	Transmit channel power down
0	X	X	X	X	X	X	X	Sidetone enabled
1	X	X	X	X	X	X	X	Sidetone muted

Table 10. Mode Control Register: Address (01) HEX

BIT NUMBER								DEFINITIONS
7	6	5	4	3	2	1	0	
0	0	0	0	0	0	1	0	Default setting
X	X	X	X	X	X	0	0	TX channel high-pass filter enabled and slope filter enabled
X	X	X	X	X	X	0	1	TX channel high-pass filter enabled and slope filter disabled
X	X	X	X	X	X	1	0	TX channel high-pass filter disabled and slope filter enabled
X	X	X	X	X	X	1	1	TX channel high-pass filter disabled and slope filter disabled
X	X	X	X	X	0	X	X	RX channel high-pass filter disabled (low pass only)
X	X	X	X	X	1	X	X	RX channel high-pass filter enabled
X	X	X	X	0	X	X	X	BUZZCON disabled
X	X	X	X	1	X	X	X	BUZZCON enabled
X	X	X	0	X	X	X	X	Linear mode selected
1	X	X	1	X	X	X	X	A-law companding mode selected
0	X	X	1	X	X	X	X	μ-law companding mode selected
X	X	0	X	X	X	X	X	TX and RX channels normal mode
X	X	1	X	X	X	X	X	PCM loopback mode
X	0	X	X	X	X	X	X	Tone mode disabled
X	1	X	X	X	X	X	X	Tone mode enabled

---

**PRINCIPLES OF OPERATION**
**register map (continued)**

Transmit PGA and sidetone control register: Address (02)HEX

Bit definitions:

7	6	5	4	3	2	1	0	DEFINITION
X	TP3	TP2	TP1	TP0	ST2	ST1	ST0	See Table 2 and Table 4
0	1	0	0	0	0	0	0	Default setting

Receive volume control register: Address (03)HEX

Bit definitions:

7	6	5	4	3	2	1	0	DEFINITION
RP3	RP2	RP1	RP0	RV3	RV2	RV1	RV0	See Table 3 and Table 5
1	0	1	0	0	0	0	0	Default setting

High tone selection control register: Address (04)HEX

Bit definitions:

7	6	5	4	3	2	1	0	DEFINITION
X	X	X	X	X	X	X	X	DTMF (see Table 7)
0	0	0	0	0	0	0	0	Default setting

Low tone selection control register: Address (05)HEX

Bit definitions :

7	6	5	4	3	2	1	0	DEFINITION
X	X	X	X	X	X	X	X	DTMF (see Table 7)
0	0	0	0	0	0	0	0	Default setting

Auxiliary register: Address (06)HEX

Bit definitions:

7	6	5	4	3	2	1	0	DEFINITION
0	0	0	0	0	0	0	0	Default
X	X	X	X	X	X	X	0	MCLK is set to 2.048 MHz
X	X	X	X	X	X	X	1	MCLK is set to 128 MHz
X	X	X	X	X	X	0	X	Analog switch output is set to OUT2
X	X	X	X	X	X	1	X	Analog switch output is set to OUT1
X	X	X	X	0	0	X	X	Low tone frequency resolution is set to 7.8125 Hz
X	X	X	X	0	1	X	X	Low tone frequency resolution is set to 15.625 Hz
X	X	X	X	1	0	X	X	Low tone frequency resolution is set to 31.250 Hz
X	X	0	0	X	X	X	X	High tone frequency resolution is set to 7.8125 Hz
X	X	0	1	X	X	X	X	High tone frequency resolution is set to 15.625 Hz
X	X	1	0	X	X	X	X	High tone frequency resolution is set to 31.250 Hz
X	0	X	X	X	X	X	X	Receiver channel gain, RXPGA2 is equal to 0 dB, voice mode only
X	1	X	X	X	X	X	X	Receiver channel gain, RXPGA2 is equal to 6 dB, voice mode only
0	X	X	X	X	X	X	X	MCLK detector is powered ON
1	X	X	X	X	X	X	X	MCLK detector is powered OFF

**PRINCIPLES OF OPERATION****using PCM codec as a general-purpose PCM codec**

In situations when a general-purpose PCM codec is needed and programming features are not necessary, the receive and transmit channels can be enabled for voice mode only by setting the powerup select pin to  $V_{CC}$  level.

When set to default, the following features are activated:

- REF is powered up
- Ear amp1 selected, Ear amp 2 = OFF
- Receive channel enabled
- MIC bias enabled
- MIC 2 selected
- Transmit channel enabled
- Side tone enabled, Gain = -12 dB
- TX channel high pass filter disabled
- TX channel slope filter enabled
- RX channel HP filter disabled (low pass only)
- Buzzcon disabled
- Linear mode only
- TX and RX channel normal mode (no loopback)
- Tone mode disabled (voice mode only)
- MIC amp 1 gain = 23.5 dB  
MIC amp 2 gain = 6 dB  
TX PGA gain = 0 dB  
Total TX gain = 29.5 dB
- Receive PGA = -4 dB  
Receive PGA 2 = 0 dB  
Volume = 0 dB  
Total RX gain = -4 dB
- Clock = 2.048 MHz

---

**PRINCIPLES OF OPERATION**
**PCM codec device comparisons**

	<b>TLV320AIC1103</b>	<b>TLV320AIC1110</b>
Single tone frequency range	To 2 kHz	To 8 kHz
Transmit channel gain range	13.5 dB to 35.5 dB	19.5 dB to 41.5 dB
Receive channel gain range	– 24 dB to 6 dB	– 24 dB to 12 dB
PCMCLK rate	2.048 MHz	128 kHz or 2.048 MHz
Device pin out	Backward compatible (TQFP)	
Control registers	Backward compatible	
Number of registers	6	7
Control interface	I <sup>2</sup> C	I <sup>2</sup> C
Analog switch	No	Yes
Earout driving impedance	32 Ω	8-32 Ω
DTMF	Yes	Yes
Tone resolution (Hz)	7.8125	7.8125 15.625 31.25
Packages	TQFP	TQFP, MicroStar Junior BGA™

MECHANICAL DATA

PBS (S-PQFP-G32)

PLASTIC QUAD FLATPACK

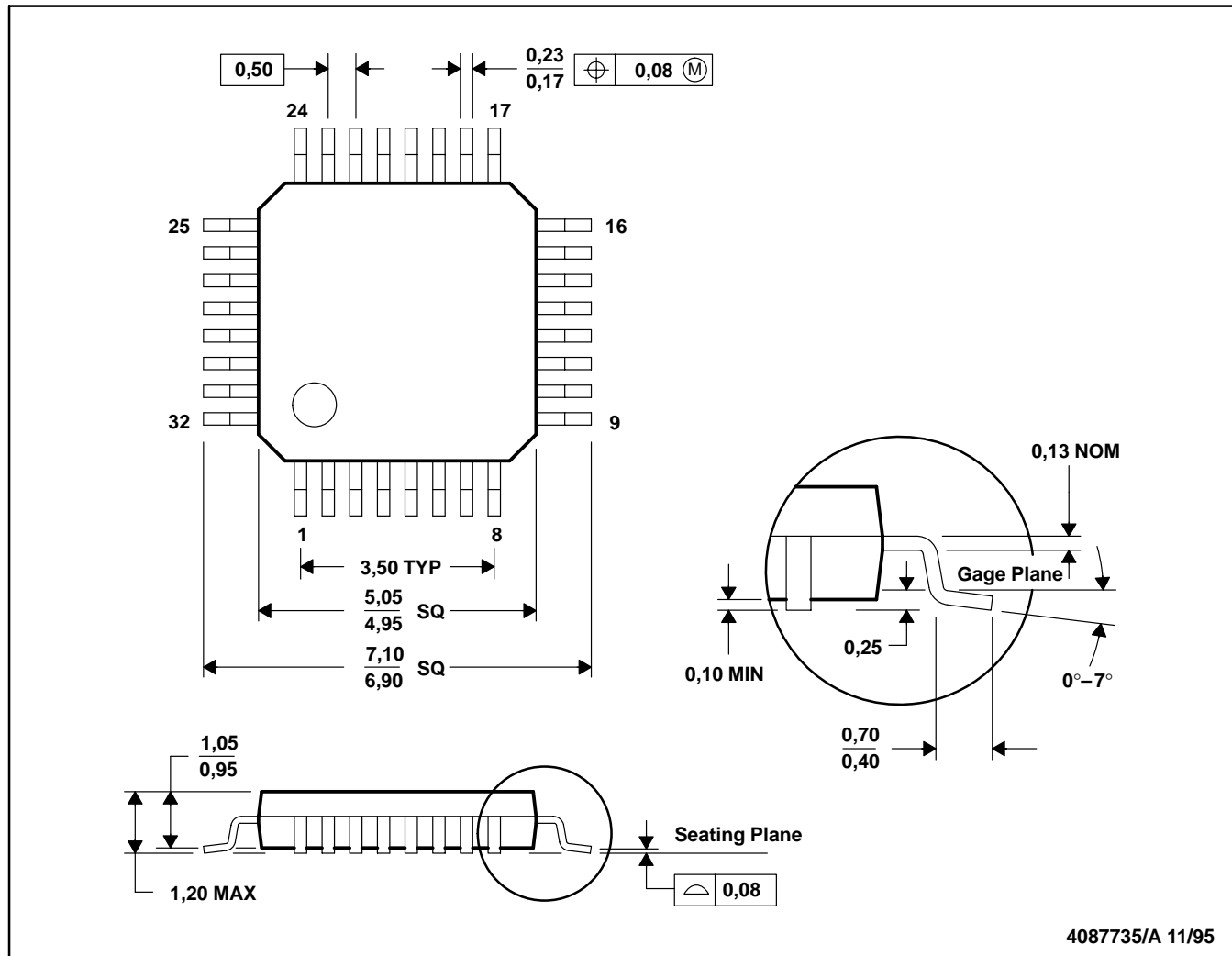

NOTES: A. All linear dimensions are in millimeters.  
 B. This drawing is subject to change without notice.

MECHANICAL DATA

GQE (S-PBGA-N80)

PLASTIC BALL GRID ARRAY

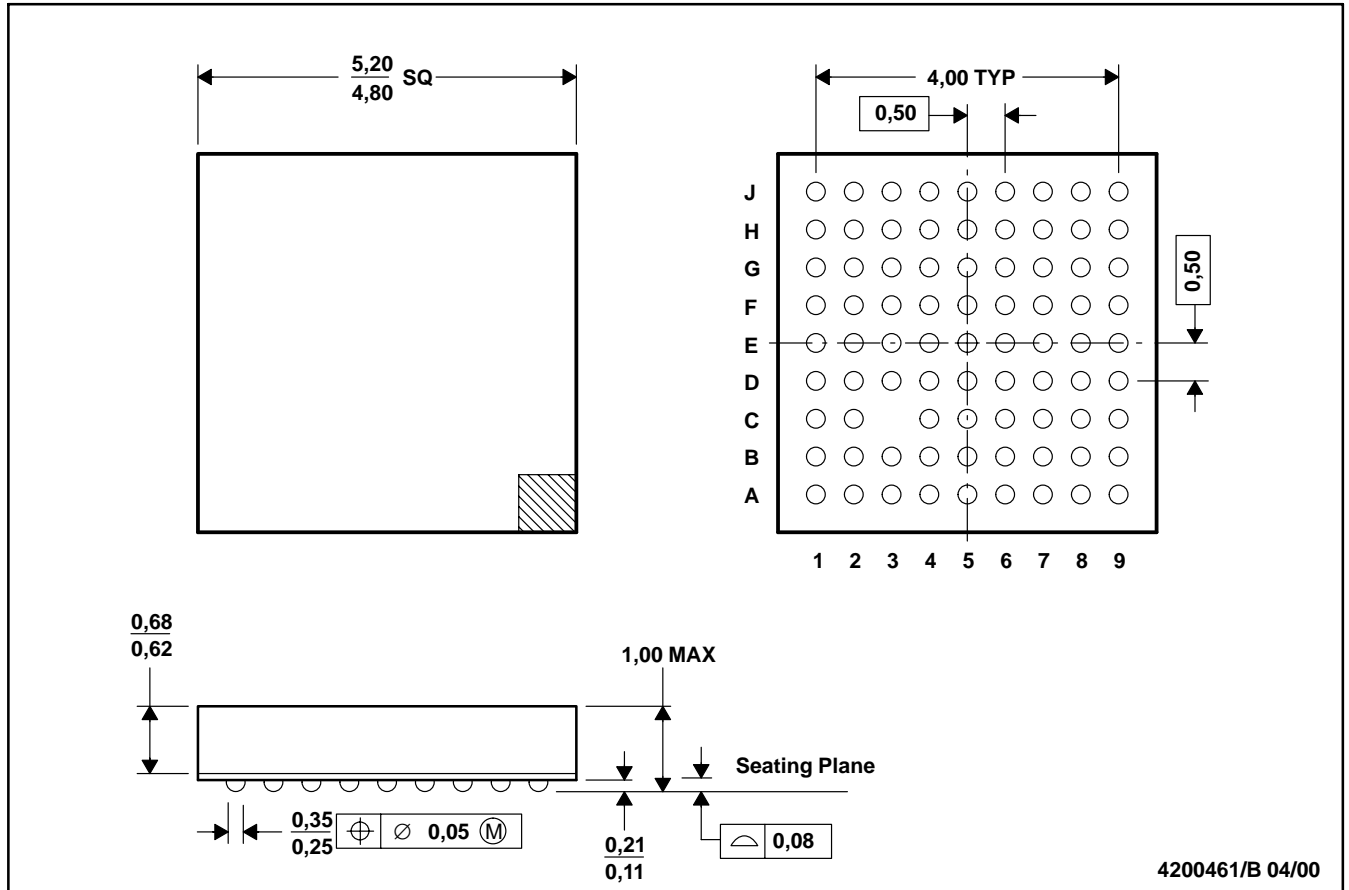

- NOTES: A. All linear dimensions are in millimeters.  
 B. This drawing is subject to change without notice.  
 C. MicroStar Junior BGA™ configuration

MicroStar Junior BGA is a trademark of Texas Instruments.

## IMPORTANT NOTICE

Texas Instruments Incorporated and its subsidiaries (TI) reserve the right to make corrections, modifications, enhancements, improvements, and other changes to its products and services at any time and to discontinue any product or service without notice. Customers should obtain the latest relevant information before placing orders and should verify that such information is current and complete. All products are sold subject to TI's terms and conditions of sale supplied at the time of order acknowledgment.

TI warrants performance of its hardware products to the specifications applicable at the time of sale in accordance with TI's standard warranty. Testing and other quality control techniques are used to the extent TI deems necessary to support this warranty. Except where mandated by government requirements, testing of all parameters of each product is not necessarily performed.

TI assumes no liability for applications assistance or customer product design. Customers are responsible for their products and applications using TI components. To minimize the risks associated with customer products and applications, customers should provide adequate design and operating safeguards.

TI does not warrant or represent that any license, either express or implied, is granted under any TI patent right, copyright, mask work right, or other TI intellectual property right relating to any combination, machine, or process in which TI products or services are used. Information published by TI regarding third-party products or services does not constitute a license from TI to use such products or services or a warranty or endorsement thereof. Use of such information may require a license from a third party under the patents or other intellectual property of the third party, or a license from TI under the patents or other intellectual property of TI.

Reproduction of information in TI data books or data sheets is permissible only if reproduction is without alteration and is accompanied by all associated warranties, conditions, limitations, and notices. Reproduction of this information with alteration is an unfair and deceptive business practice. TI is not responsible or liable for such altered documentation.

Resale of TI products or services with statements different from or beyond the parameters stated by TI for that product or service voids all express and any implied warranties for the associated TI product or service and is an unfair and deceptive business practice. TI is not responsible or liable for any such statements.

### Mailing Address:

Texas Instruments  
Post Office Box 655303  
Dallas, Texas 75265